

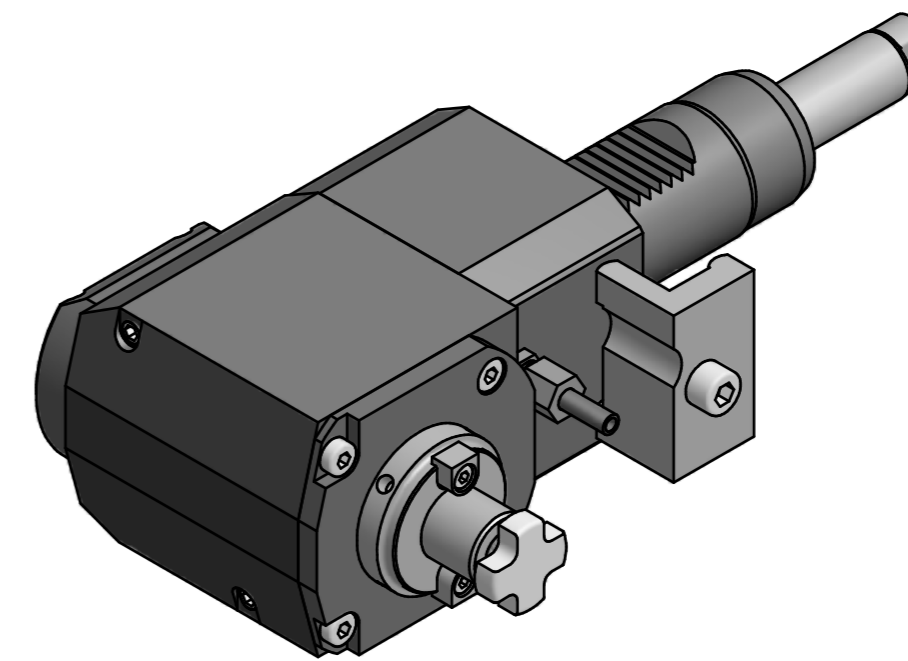

Hakenschlüssel
mit Zapfen
Hook wrench
with fixed pin
DIN1810 B 45x50



Copyright **EWS Tool Technologies**
Weitergabe und Vervielfältigung dieser Unterlage,
Verwertung und Mitteilung ihres Inhalts nicht
gestattet, soweit nicht ausdrücklich zugestanden.
Zuwerhandlungen verpflichten zu Schadenersatz.

Bemerkung - Note	Technische Daten - technical data		Benennung - Title	Technische Änderungen vorbehalten! Subject to technical modifications! Nr. 62.4022KRVTCLX100 File: D-EWS-173463-ldw
	mit Kegelrollenlager with taper roller bearing(s)	$M_1 / M_2 = 50 / 50 \text{ Nm}$ $n_1 / n_2 = 5000 / 5000 \text{ 1/min}$ $i (N_1:N_2) = 1:1$		

