

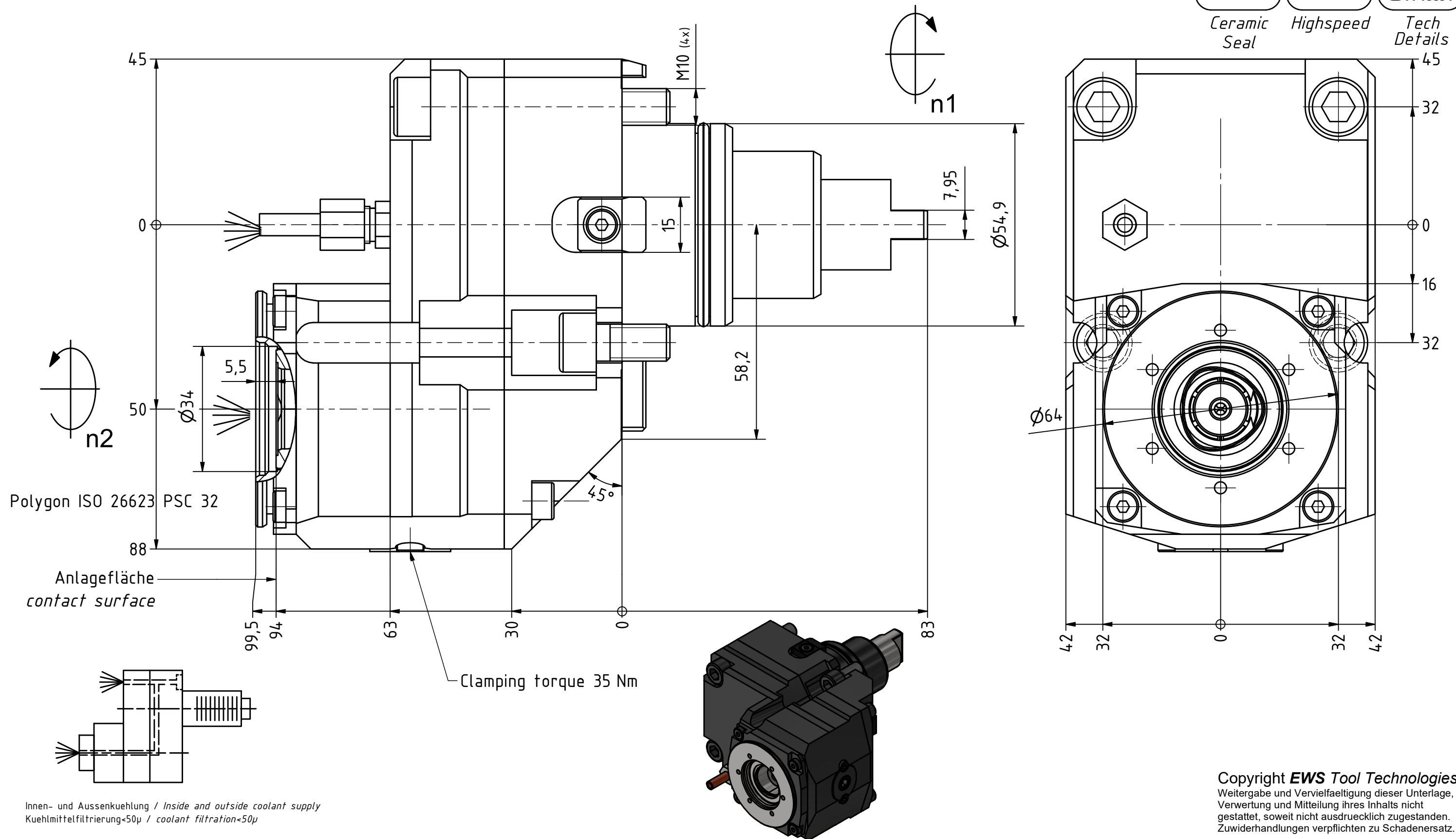

Ceramic Seal

Highspeed

Tech Details



Bemerkung - Note  
 Für Trockenlauf geeignet!  
 Use without coolant fluid allowed!

Technische Daten - technical data	
Weight	= 6.077 [kg]
Torque max. (M1/M2)	= 40 / 20 [Nm]
Speed max. (n1/n2)	= 6000 / 12000 [1/min]
Gear ratio (i)=n1:n2	= 1:2
Pressure (pmax)	= 70 [bar]

Benennung - Title  
**Axial Bohr u. Fräskopf achsversetzt**  
**Ax. drill. and mill. head offset**

**EWS** Tool Technologies  
 EWS Weigle GmbH & Co. KG  
 Maybachstr. 1  
 D-73066 UHINGEN  
 www.ews-tools.de

Nr. - No.  
**50.55C3VL2IKDI1**

Technische Aenderungen vorbehalten!  
 Subject to technical modifications!

IDENT: DEWS239308  
 REV: -/D  
 MNR.  
**180008**



Copyright **EWS Tool Technologies**  
 Weitergabe und Vervielfaeltigung dieser Unterlage,  
 Verwertung und Mitteilung ihres Inhalts nicht  
 gestattet, soweit nicht ausdrecklich zugestanden.  
 Zuwiderhandlungen verpflichten zu Schadenersatz.