

Spannzange / collet ER20 DIN6499
Spannbereich / clamping range: 1,0 - 13,0

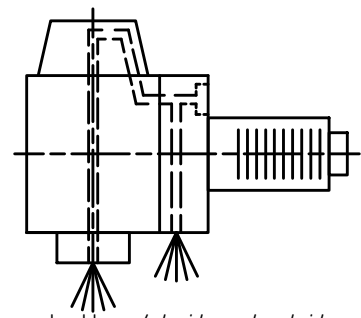

Innen- und Aussenkuehlung / Inside and outside coolant supply
Kein Trockenlauf / No dry run
Kuehlmittelfiltrierung 50μ / coolant filtration 50μ

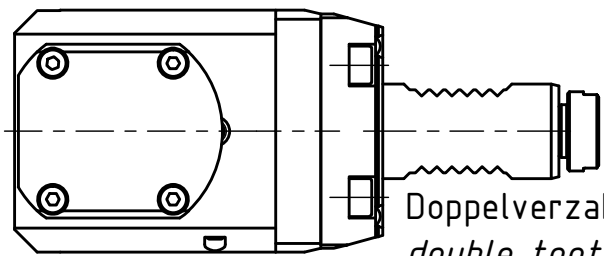

Doppelverzahnung Lizenz Traub
double tooth system licence Traub

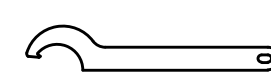
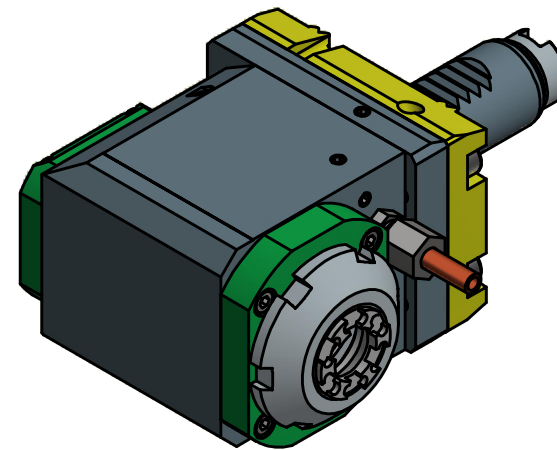

Hakenschlüssel
mit Nase
Hook wrench with
nose end
DIN1810 A 52x55

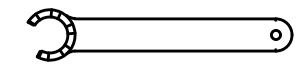

Spannzangenschlüssel für
innenliegende Mutter
Clamping wrench for
internal collet
220AX

Copyright **EWS Tool Technologies**
Weitergabe und Vervielfaeltigung dieser Unterlage,
Verwertung und Mitteilung ihres Inhalts nicht
gestattet, soweit nicht ausdruercklich zugestanden.
Zuwiderhandlungen verpflichten zu Schadenersatz.

Bemerkung - Note
Nicht ohne Kuehlmittel betreiben!
Not for use without coolant-fluid!

Technische Daten - technical data
Weight = 3.362 [kg]
Torque max. (M1/M2) = 25 / 25 [Nm]
Speed max. (n1/n2) = 8000 / 8000 [1/min]
Gear ratio (i)=n1:n2 = 1:1
Pressure (pmax) = [bar]

Benennung - Title
Radial Bohr und Fräskopf
Radial drilling and milling head

EWS
Tool Technologies
EWS Weigle GmbH & Co. KG
Maybachstr. 1
D-73066 Uthingen
www.ews-tools.de

Technische Aenderungen vorbehalten!
Subject to technical modifications!

IDENT: DEWS128664

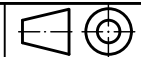

REV: -/A

Nr. - No.

60.2520G200RLWIM

MNR.

180732

QR