

Z (2:1)

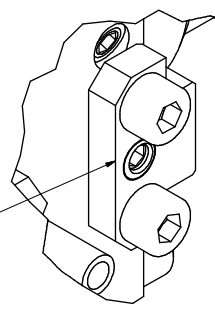

Ausrichtklotz ist über ein Exzenter einstellbar.
The block is adjustable via eccentric.

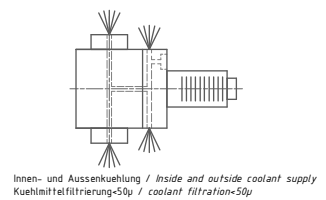
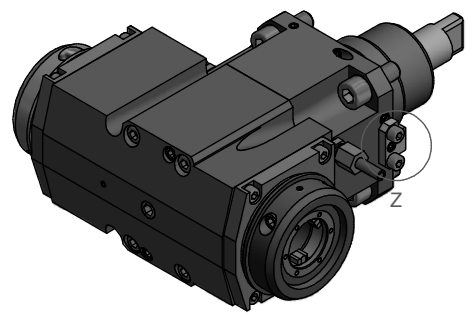

Innen- und Aussenkuehlung / Inside and outside coolant supply
Kuehlmittelfiltrierung=50µ / coolant filtration=50µ

| | | | |
|--|--|--|--|
| <p>Bemerkung - Note Für Trockenlauf geeignet! Use without coolant fluid allowed!</p> | <p>Technische Daten - Technical data Weight = 10.532 [kg] Torque max. (M1/M2) = 50 / 50 each Sp. [Nm] Speed max. (n1/n2) = 10000 / 10000 [1/min] Gear ratio (i)=n1:n2 = 1:1 Pressure (pmax) = 70 [bar]</p> | <p>Benennung - Title Radial Bohr und Fräskopf Radial drilling and milling head</p> | <p>Copyright EWS Tool Technologies Weitergabe und Vervielfältigung dieser Unterlage, Verwertung und Mitteilung ihres Inhalts nicht gestattet, soweit nicht ausdrücklich zugestanden. Zuwiderhandlungen verpflichten zu Schadenersatz. Technische Änderungen vorbehalten! Subject to technical modifications! EWS Tool Technologies EWS Werkzeug GmbH & Co. KG D-72086 Löhningen www.ews-tool.de IDENT: DEWS022960 REV: -/A 180356</p> |
|--|--|--|--|

