

beidseitige Montage möglich  
double-sided mounting possible

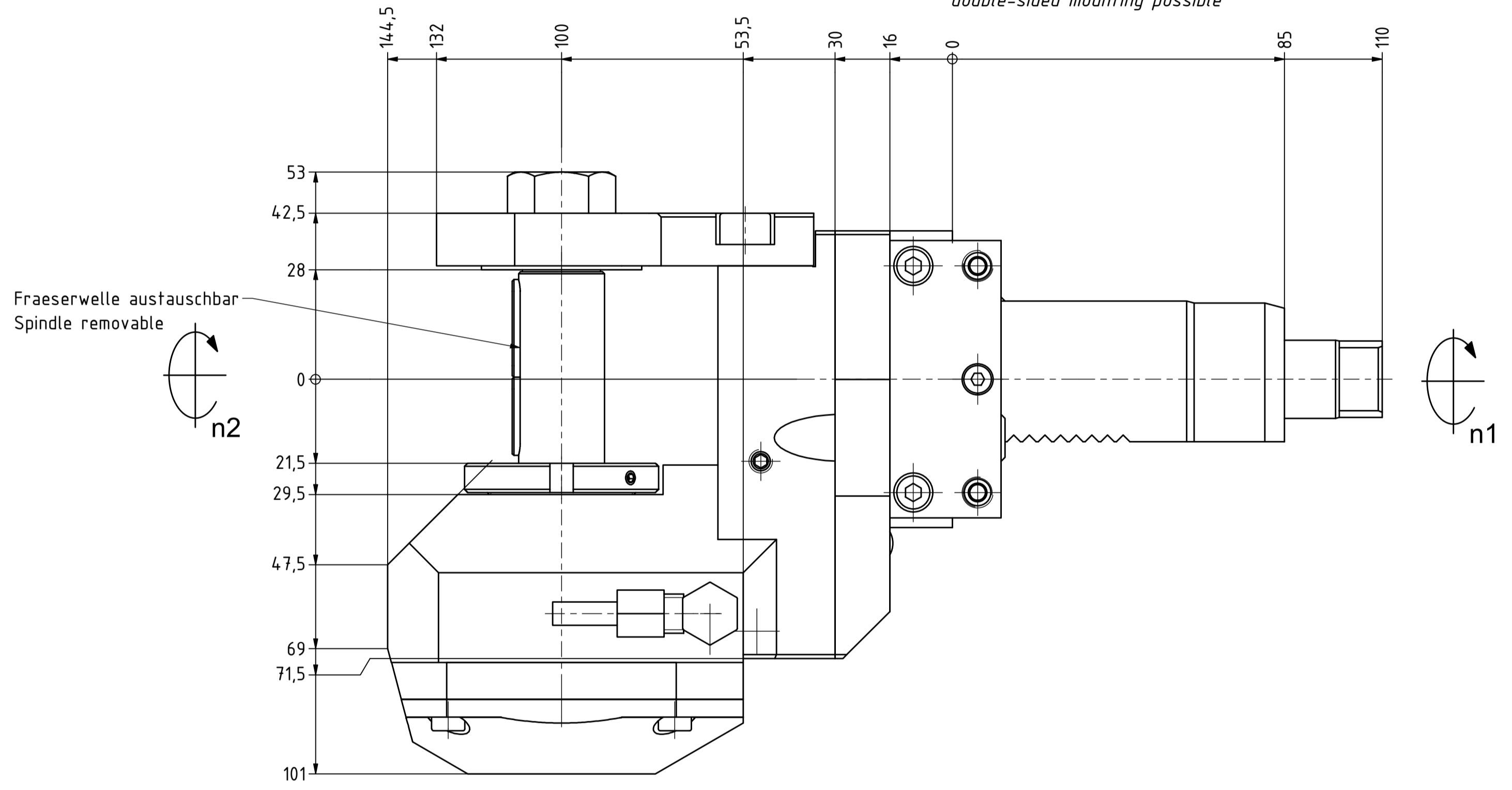

Fraeserwelle austauschbar  
Spindle removable

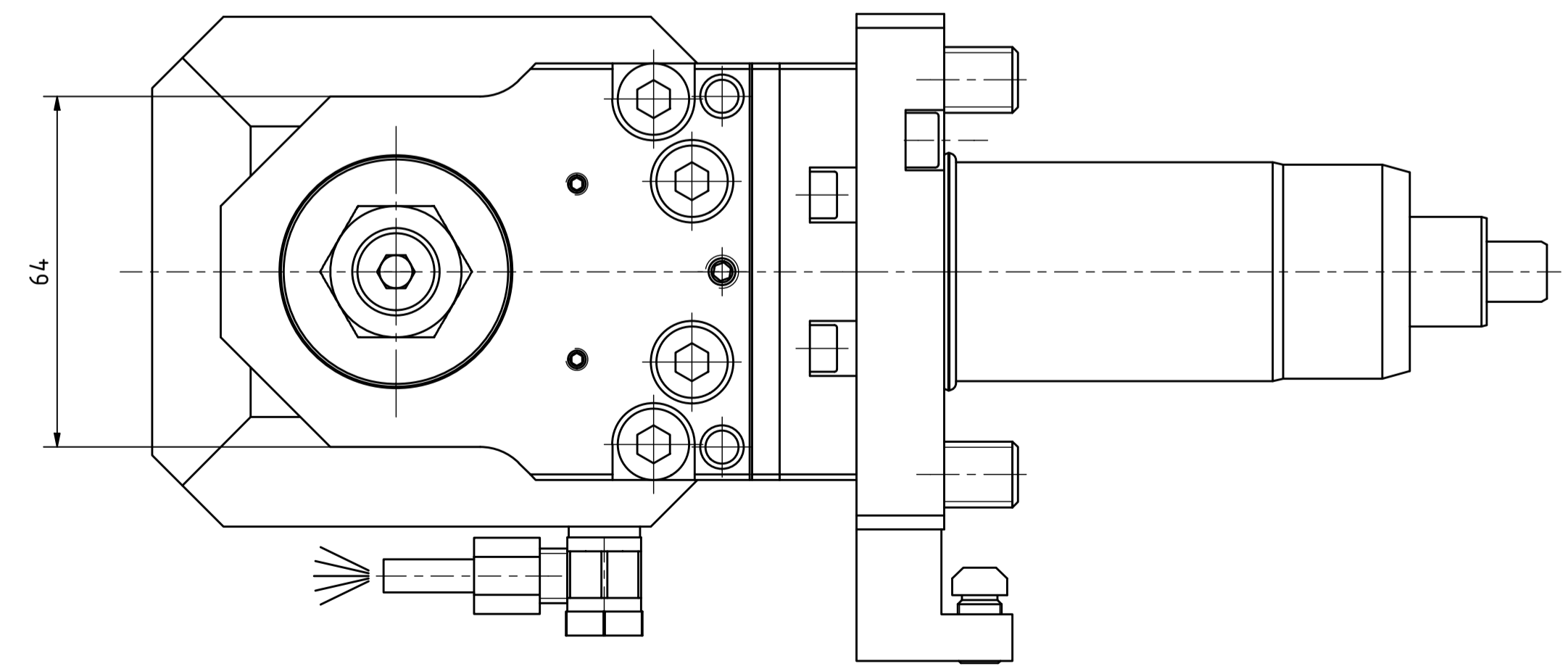
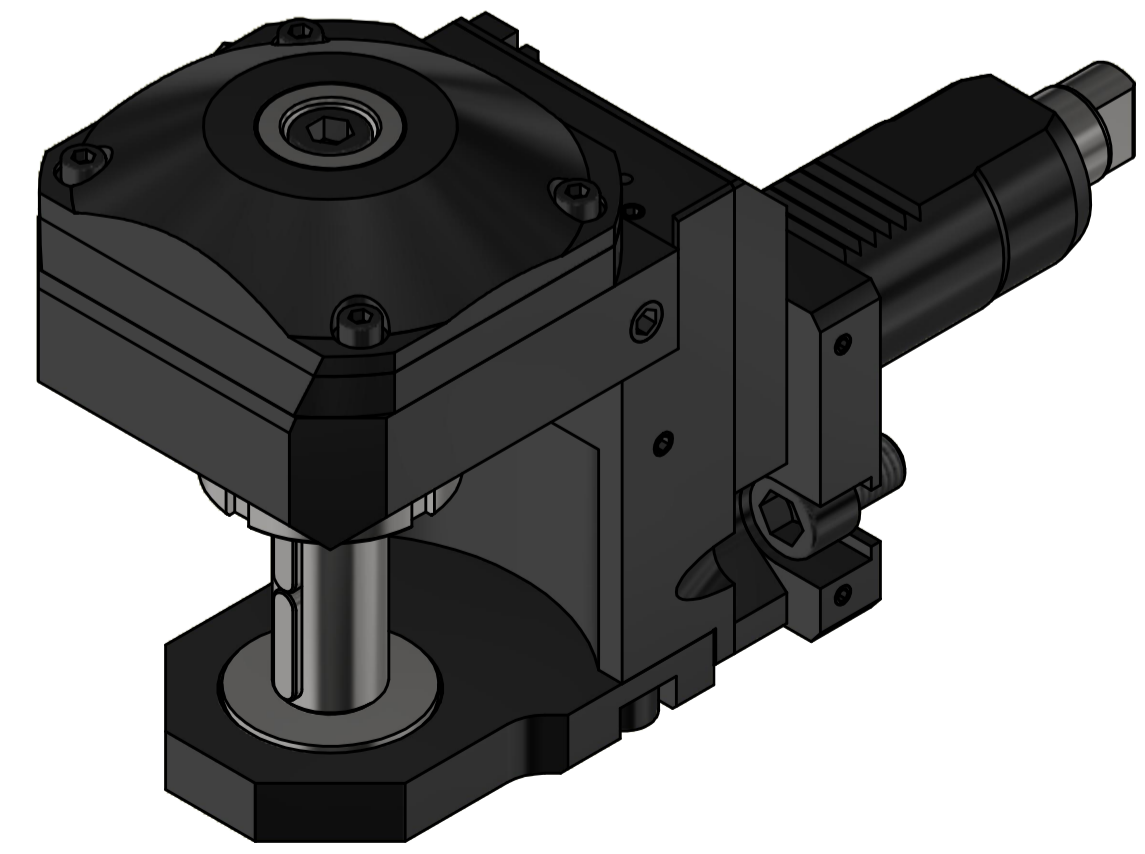
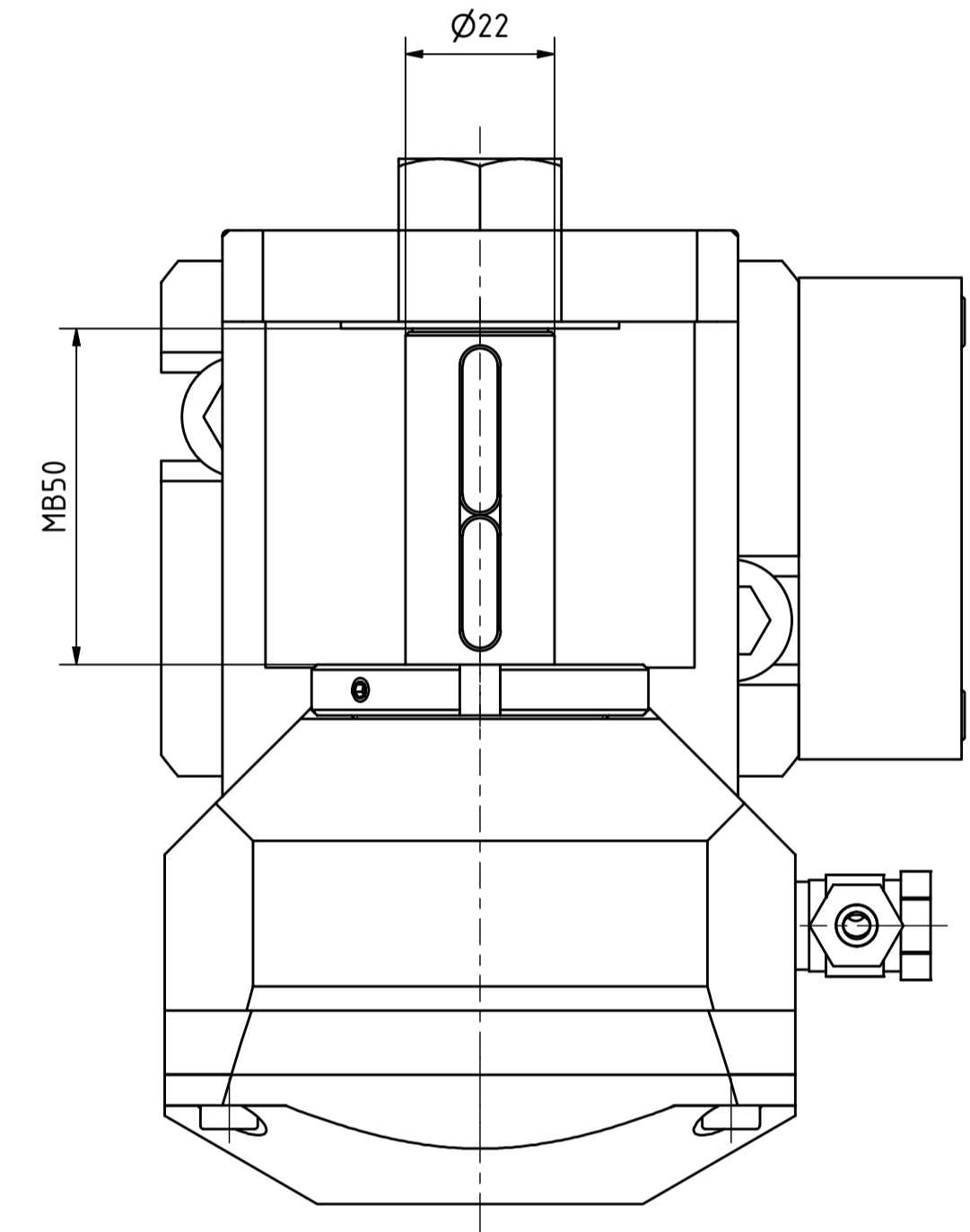

Bemerkung - Note

Technische Daten - technical data  
 Weight = 8,253 [kg]  
 Torque max. (M1/M2) = 50 / 150 [Nm]  
 Speed max. (n1/n2) = 6000 / 2000 [1/min]  
 Gear ratio (i)=n1:n2 = 3:1

Bezeichnung - Title  
**Scheibenfräserkopf**  
 Radial saw milling head

 <small>EWS Werkzeug GmbH &amp; Co. KG        Hauptwerk 1        64700 Kelkheim        www.ews-tool.de</small>	<small>Technische Änderungen vorbehalten!</small> <small>Subject to technical modifications!</small>	 <small>REV. - / A</small>
	<small>IDENT: DEWS230221</small>	
<small>Nr. - No.</small> <b>64.4022LVL313-VS</b>	<small>HRB.</small> <b>179099</b>	<b>QR</b>

Copyright EWS Tool Technologies  
 Weitergabe und Vervielfältigung dieser Unterlage,  
 Verwertung und Mitteilung ihres Inhalts nicht  
 gestattet, soweit nicht ausdrücklich zugestanden.  
 Zuwiderhandlungen verpflichten zu Schadenersatz.