

Fraeserwelle austauschbar
spindle removable

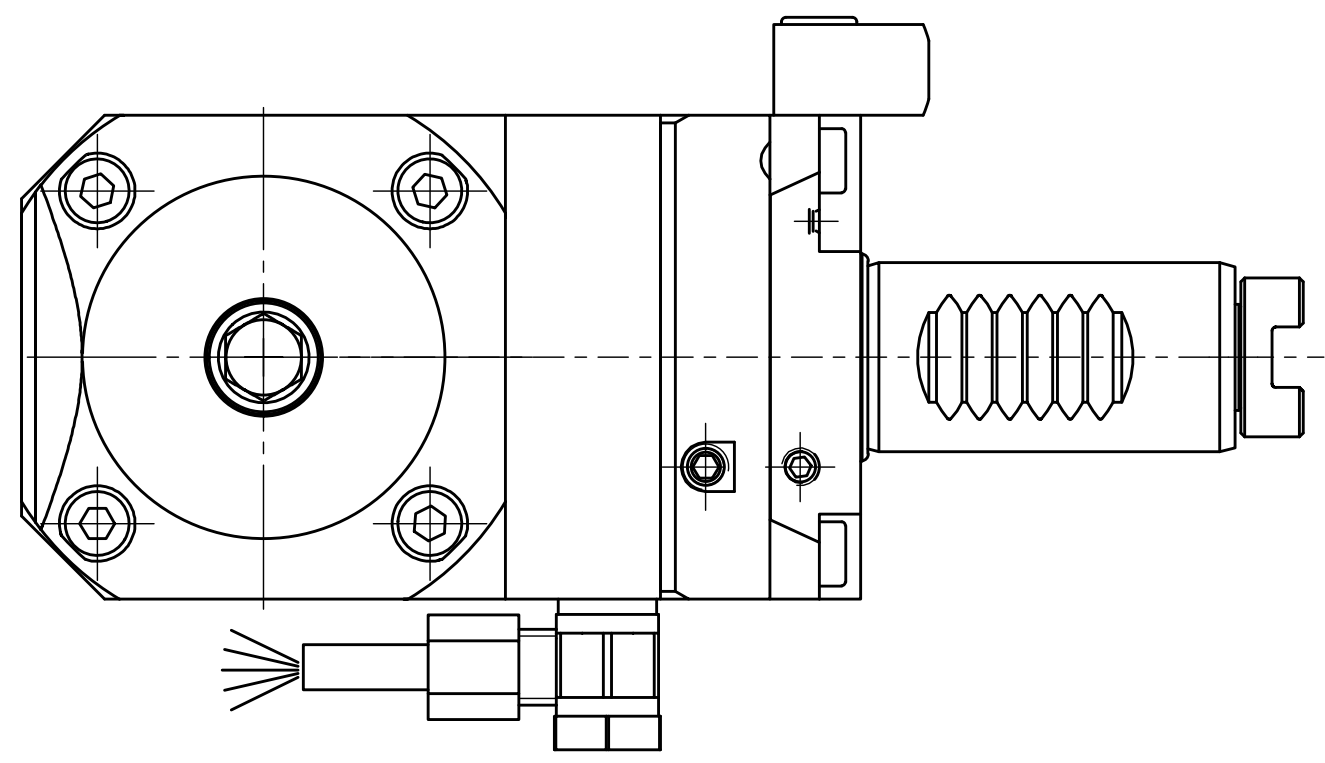
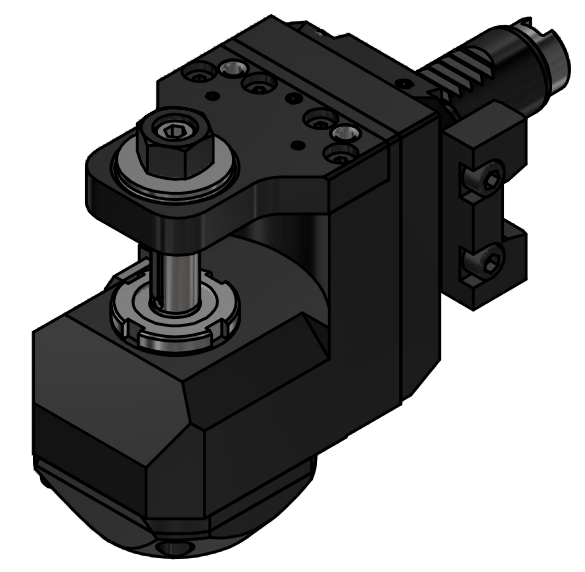

Copyright **EWS Tool Technologies**
Weitergabe und Vervielfältigung dieser Unterlage,
Verwertung und Mitteilung ihres Inhalts nicht
gestattet, soweit nicht ausdrücklich zugestanden.
Zuwerhandlungen verpflichten zu Schadenersatz.

Bemerkung - Note 	Technische Daten - technical data Weight = 3.657 [kg] Torque max. (M1/M2) = 20 / 60 [Nm] Speed max. (n1/n2) = 6000 / 2000 [1/min] Gear ratio (i)=n1:n2 = 3:1	Benennung - Title Scheibenfräserkopf Radial saw milling head	EWS Tool Technologies <small>EWS Weigle GmbH & Co. KG Maybachstr. 1 D-73066 Ulm/ingen www.ews-tools.de</small>	Technische Änderungen vorbehalten! Subject to technical modifications! IDENT: DEWS041757 REV: -/B MNR. 207426	
----------------------	--	--	---	--	---