

Spannzange / collet ER40 DIN6499  
Spannbereich / clamping range: 3,0 - 26,0

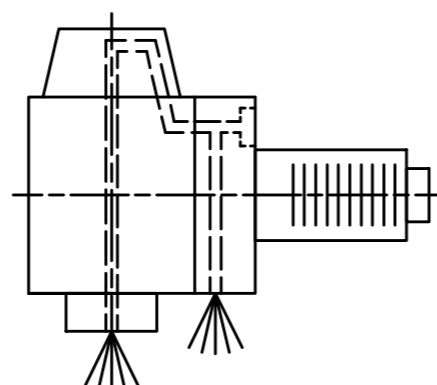

Innen- und Aussenkuehlung / Inside and outside coolant supply  
Kuehlmittelfiltrierung=50µ / coolant filtration=50µ

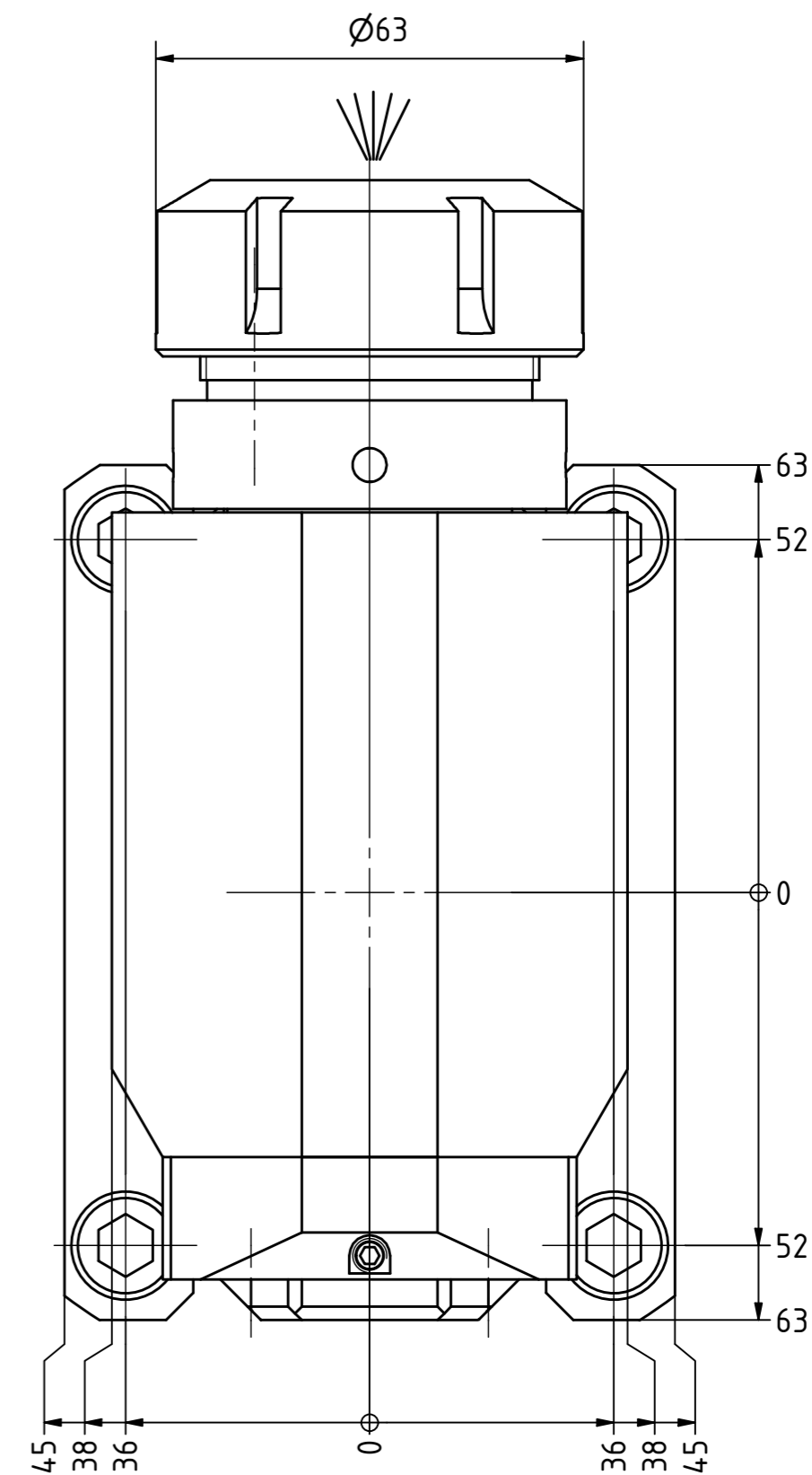
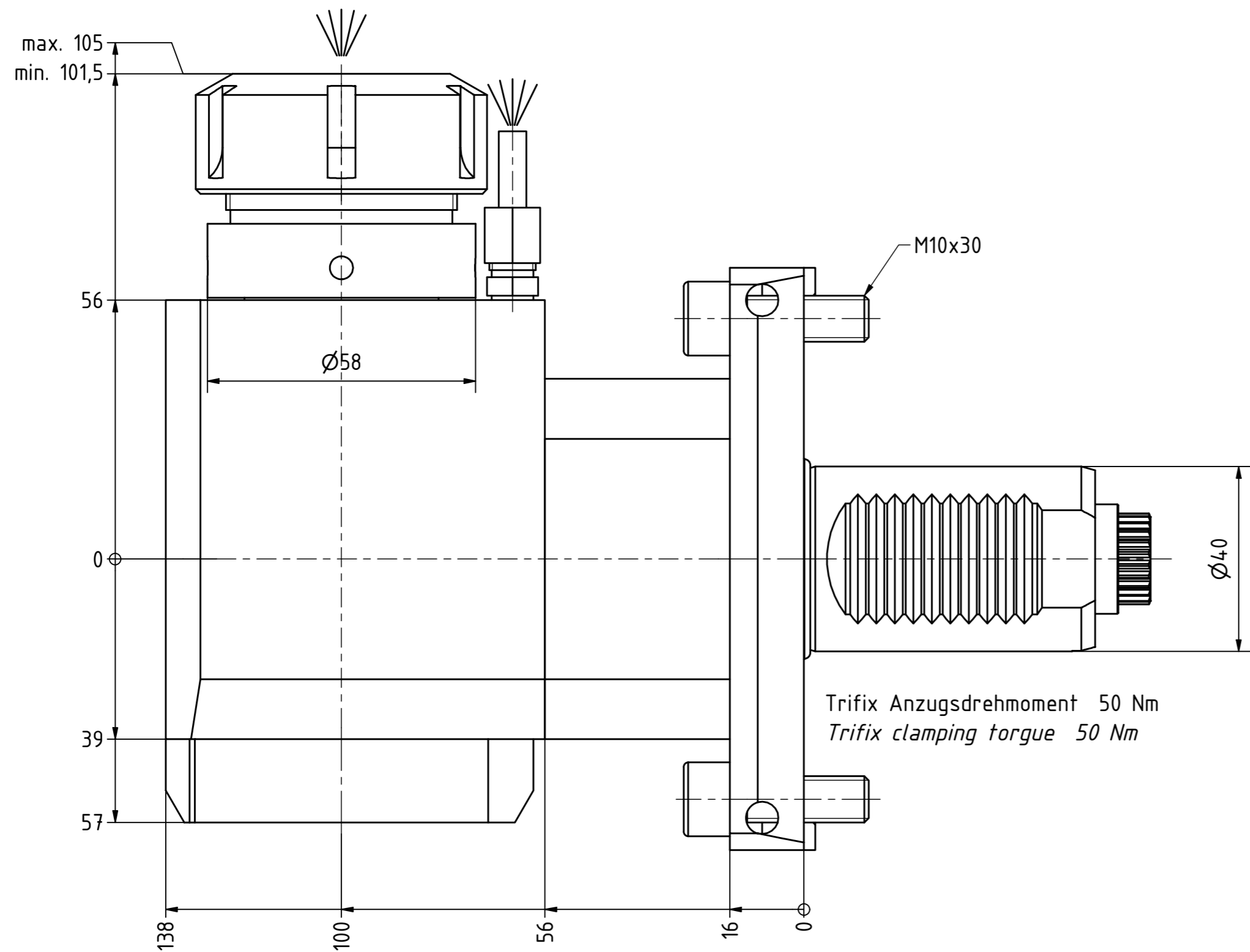
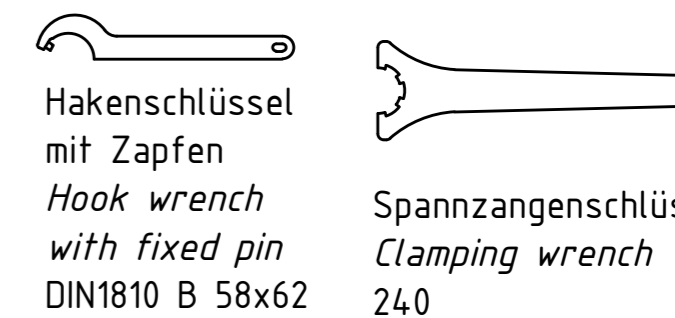
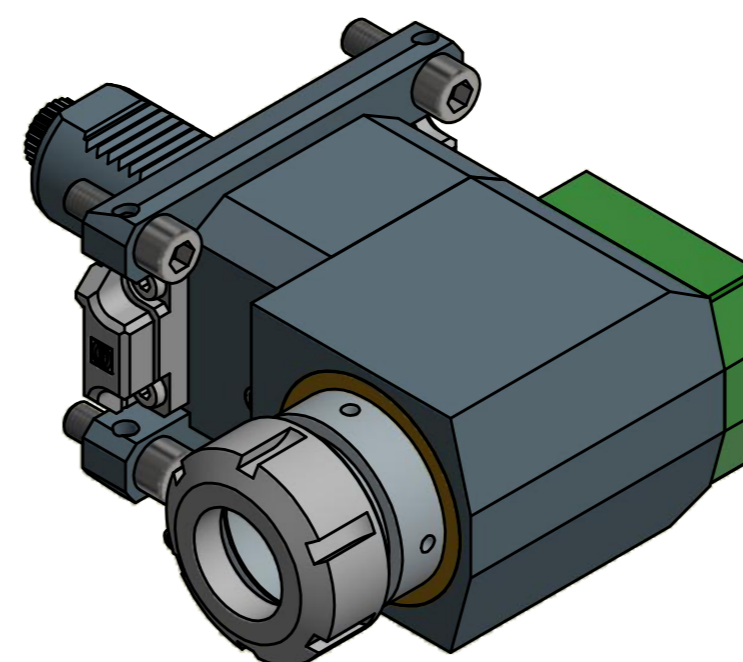

Hakenschlüssel mit Zapfen  
Hook wrench with fixed pin  
DIN1810 B 58x62

Spannzangenschlüssel  
Clamping wrench  
240

Copyright **EWS Tool Technologies**  
Weitergabe und Vervielfaeltigung dieser Unterlage, Verwertung und Mitteilung ihres Inhalts nicht gestattet, soweit nicht ausdrecklich zugestanden. Zuwiderhandlungen verpflichten zu Schadenersatz.

Bemerkung - Note  
Für Trockenlauf geeignet!  
Use without coolant fluid allowed!  
mit Kegelrollenlager  
with taper roller bearing(s)

Technische Daten - technical data  
Weight = 8.154 [kg]  
Torque max. (M1/M2) = 40 / 80 [Nm]  
Speed max. (n1/n2) = 6000 / 3000 [1/min]  
Gear ratio (i)=n1:n2 = 2:1  
Pressure (pmax) = 70 [bar]

Benennung - Title  
Radial Bohr und Fräskopf  
Radial drilling and milling head

|  |   |   |          |
|--|---|---|----------|
|  | EWS Weigle GmbH & Co. KG<br>Maybachstr. 1<br>D-73066 Uhlingen<br>www.ews-tools.de | Technische Aenderungen vorbehalten!<br>Subject to technical modifications!<br>IDENT: DEWS038488 |          |
|  | Nr. - No.<br>60.4040KRCTXLIKDI2TF-PL  | MNR.<br>206861  | REV: -/A |

QR