

EWS-Varia VX4

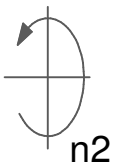

Anlagefläche
contact surface

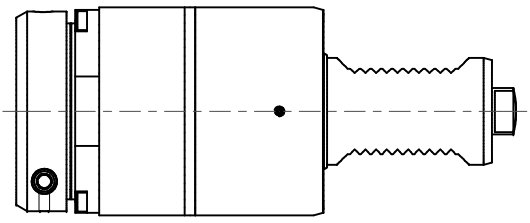
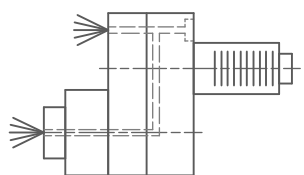
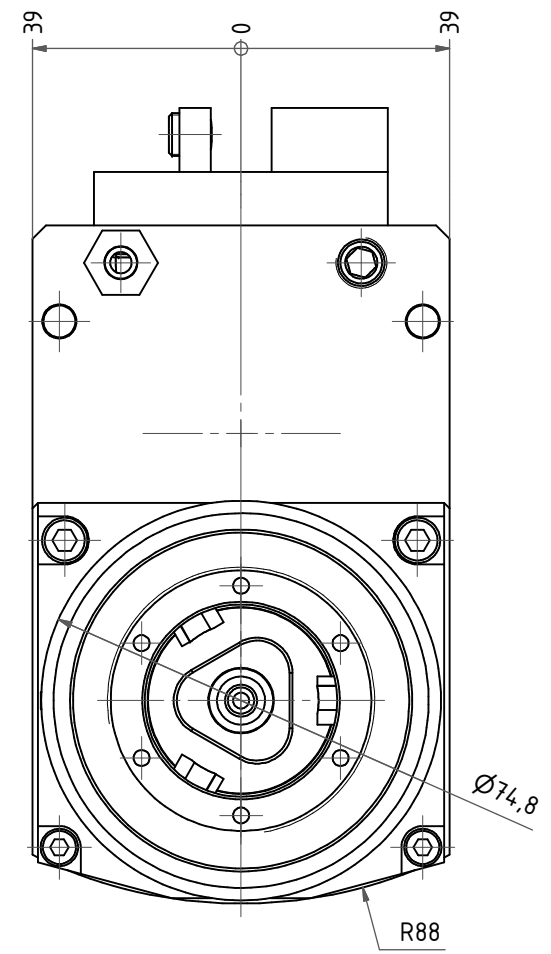
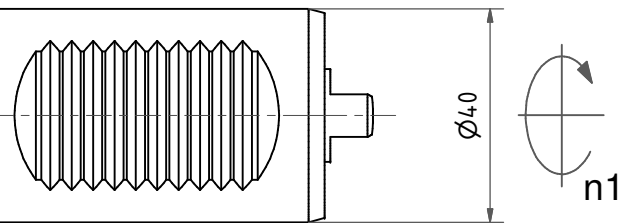

Doppelverzahnung Lizenz Traub
double tooth system licence Traub

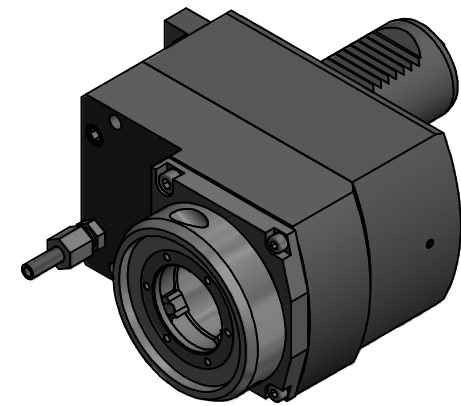

Copyright **EWS Tool Technologies**
Weitergabe und Vervielfältigung dieser Unterlage,
Verwertung und Mitteilung ihres Inhalts nicht
gestattet, soweit nicht ausdrücklich zugestanden.
Zu widerhandlungen verpflichten zu Schadenersatz.

Bemerkung - Note
Nicht ohne Kuehlmittel betreiben!
Not for use without coolant-fluid!

Technische Daten - technical data	
Weight	= 6.677 [kg]
Torque max. (M1/M2)	= 50 / 25 [Nm]
Speed max. (n1/n2)	= 5000 / 10000 [1/min]
Gear ratio (i)=n1:n2	= 1:2
Pressure (pmax)	= 70 [bar]

Benennung - Title

EWS
Tool Technologies
EWS Weigelt GmbH & Co. KG
Maybachstr. 1
D-73066 Ulmingen
www.ews-tools.de

Technische Aenderungen vorbehalten! Subject to technical modifications!	
IDENT: DEWS039927	REV: -/A
Nr. - No.	MNR.

50.40VX41809RLIK11FEPIN56

206233

