

Doppelverzahnung Lizenz Traub  
double tooth system licence Traub

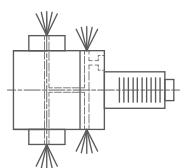
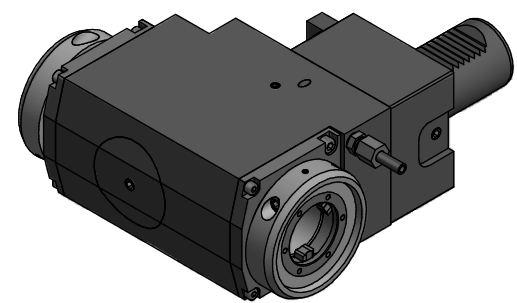

Innen- und Aussenkuehlung / Inside and outside coolant supply  
Kein Trockenlauf / No dry run  
Kuehmittelfiltrierung-50µ / coolant filtration-50µ

Bemerkung - Note	Technische Daten - Technical data	Bemerkung - Note
Nicht ohne Kuehmittel betreiben! Not for use without coolant-fluid!	Weight = 10.603 [kg] Torque max. (M1/M2) = 50 / 25 [Nm] Speed max. (n1/n2) = 5000 / 10000 [1/min] Gear ratio (i):n1:n2 = 1:2 Pressure (pmax) = 25 [bar]	

Copyright **EWS Tool Technologies**  
Weitergabe und Vervielfaeltigung dieser Unterlage,  
Verwertung und Mitteilung ihres Inhalts nicht  
gestattet, soweit nicht ausdrecklich zugestanden.  
Zuwiderhandlungen verpflichten zu Schadenersatz.

	<small>EWS Werkzeug GmbH &amp; Co. KG Marschweg 1 D-72086 Löhningen www.ewstool.de</small>	<small>Technische Änderungen vorbehalten! Subject to technical modifications!</small>	
	<small>IDENT: DEWS04-0927</small>	<small>REV: -/B</small>	
<small>Nr. - No</small> <b>80.40VX4D1809RLIK11FEPIN56X120</b>	<small>798R</small> <b>206204</b>		