

Spannzange / collet ER25 DIN6499  
 Spannbereich / clamping range: 1,0 - 16,0

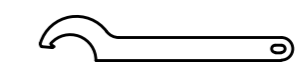

Hakenschlüssel  
 mit Nase  
 Hook wrench with  
 nose end  
 DIN1810 A 58x62

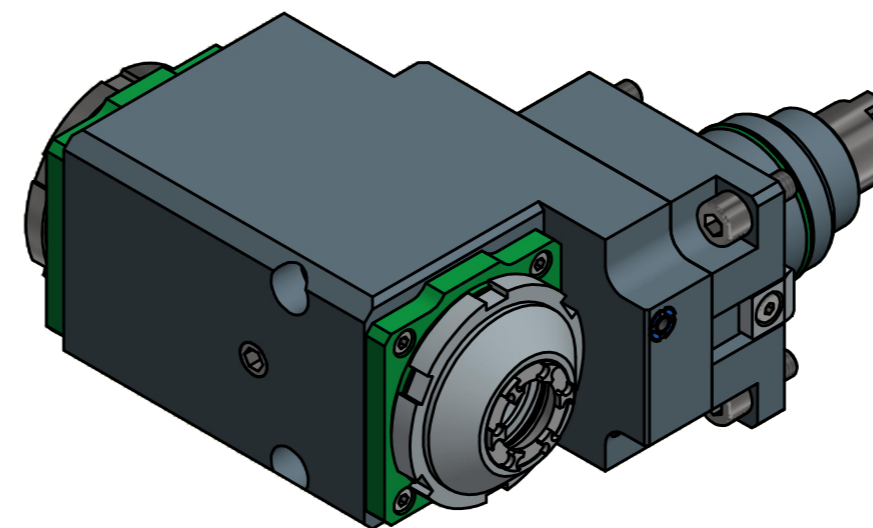

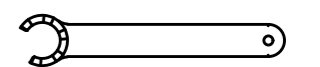

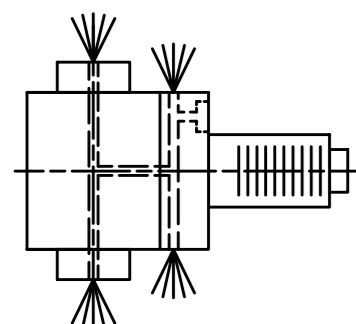
Spannzangenschlüssel für  
 innenliegende Mutter  
 Clamping wrench for  
 internal collet  
 232AX



Innen- und Aussenkühlung / Inside and outside coolant supply  
 Kein Trockentlauf / No dry run  
 Kühlmittelfiltrierung <math>50\mu</math> / coolant filtration <math>50\mu</math>

Copyright **EWS Tool Technologies**  
 Weitergabe und Vervielfältigung dieser Unterlage,  
 Verwertung und Mitteilung ihres Inhalts nicht  
 gestattet, soweit nicht ausdrücklich zugestanden.  
 Zuwiderhandlungen verpflichten zu Schadenersatz.

Bemerkung - Note Nicht ohne Kuehlmittel betreiben! Not for use without coolant-fluid!	Technische Daten - technical data Weight = 7,776 [kg] Torque max. (M1/M2) = 25 / 25   25 [Nm] Speed max. (n1/n2) = 6000 / 6000   6000 [1/min] Gear ratio (i)=n1:n2 = 1:1   1:1 Pressure (pmax) = 25 [bar]	Benennung - Title <b>Radial Bohr und Fräskopf, zurückges</b> <b>Radial drill. and mill. head offset</b>	 EWS Weigle GmbH & Co. KG Maybachstr. 1 D-73066 Uhlingen www.ews-tool.de Nr. - No. <b>80.4525DTC600IKIMX85</b>	Technische Aenderungen vorbehalten! Subject to technical modifications! IDENT: DEWS118808 REV: -/B MNR. <b>206806</b>	
---	--	---	---	--	---