

Spannzange / collet ER40 DIN6499
 Spannungsbereich / clamping range: 3,0 - 26,0

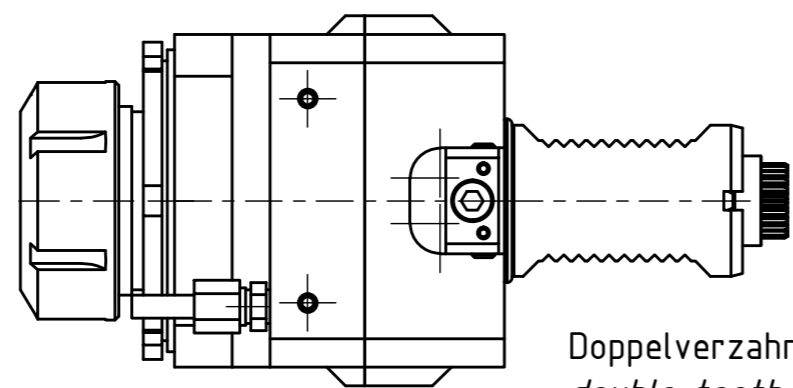

Doppelverzahnung Lizenz Traub
 double tooth system licence Traub

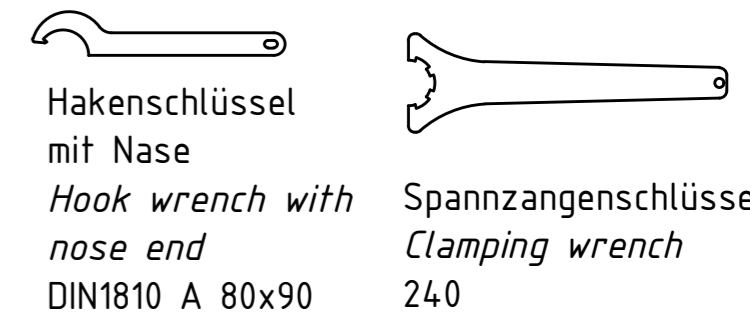
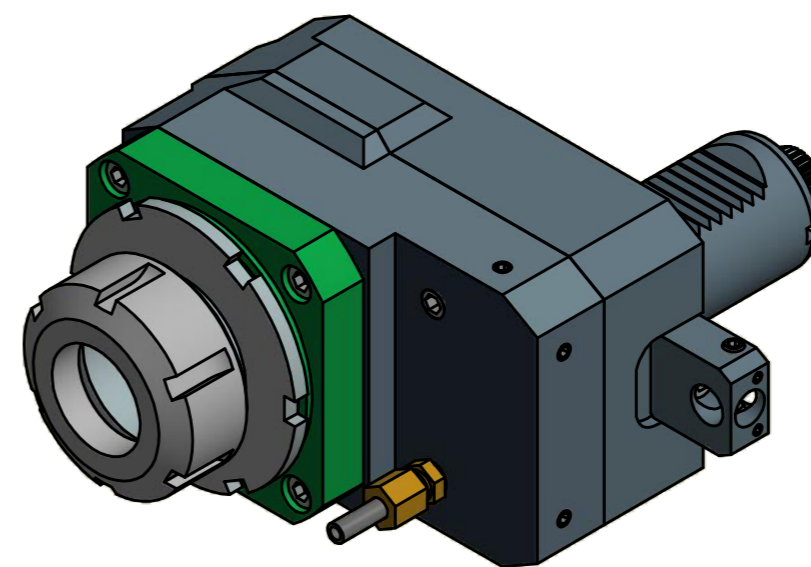

Hakenschlüssel mit Nase
 Hook wrench with nose end
 DIN1810 A 80x90

Spannzangenschlüssel
 Clamping wrench
 240

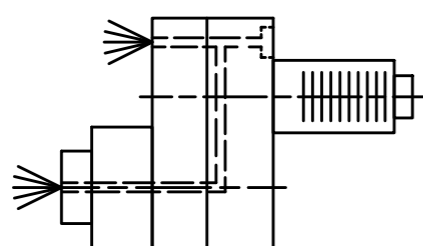

Innen- und Aussenkuehlung / Inside and outside coolant supply
 Kein Trockenlauf / No dry run
 Kuehlmittelfiltrierung 50μ / coolant filtration 50μ

Bei Sternrevolver muss der zweite Pin entfernt werden!
 On star turret, the secondary pin must be pulled out!

Copyright **EWS Tool Technologies**
 Weitergabe und Vervielfaeltigung dieser Unterlage,
 Verwertung und Mitteilung ihres Inhalts nicht
 gestattet, soweit nicht ausdrecklich zugestanden.
 Zuwiderhandlungen verpflichten zu Schadenersatz.

Bemerkung - Note Nicht ohne Kuehlmittel betreiben! Not for use without coolant-fluid! mit Kegelrollenlager with taper roller bearing(s)	Technische Daten - technical data Weight = 7.893 [kg] Torque max. (M1/M2) = 40 / 120 [Nm] Speed max. (n1/n2) = 6000 / 2000 [1/min] Gear ratio (i)=n1:n2 = 3:1 Pressure (pmax) = 70 [bar]	Benennung - Title
---	---	-------------------

EWS Tool Technologies <small>EWS Weigle GmbH & Co. KG Maybachstr. 1 D-73066 Uhlingen www.ews-tools.de</small>	Technische Aenderungen vorbehalten! Subject to technical modifications! IDENT: DEWS037607	REV: -/A MNR.
	Nr. - No. 50.4040KRCTXRLIK13	206406

