

Spannzange / collet ER20 DIN6499  
 Spannbereich / clamping range: 1,0 - 13,0

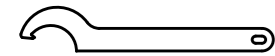

Hakenschlüssel  
 mit Nase  
 Hook wrench with  
 nose end  
 DIN1810 A 45x50

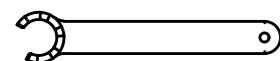

Spannzangenschlüssel für  
 innenliegende Mutter  
 Clamping wrench for  
 internal collet  
 225AX

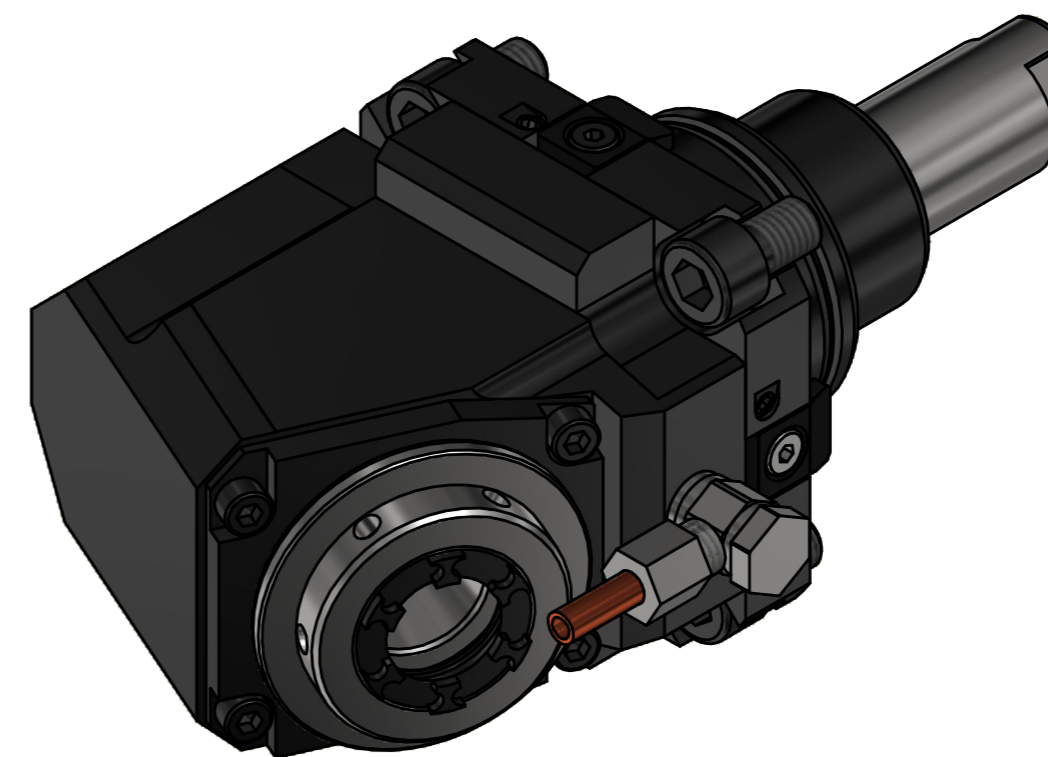

Copyright **EWS Tool Technologies**  
 Weitergabe und Vervielfältigung dieser Unterlage,  
 Verwertung und Mitteilung ihres Inhalts nicht  
 gestattet, soweit nicht ausdrücklich zugestanden.  
 Zuwiderhandlungen verpflichten zu Schadenersatz.

Bemerkung - Note  
 Nicht ohne Kuehlmittel betreiben!  
 Not for use without coolant-fluid!

Technische Daten - technical data  
 Weight = 3.846 [kg]  
 Torque max. (M1/M2) = 25 / 25 [Nm]  
 Speed max. (n1/n2) = 6000 / 6000 [1/min]  
 Gear ratio (i)=n1:n2 = 1:1  
 Pressure (pmax) = 70 [bar]

Benennung - Title  
**Radial Bohr und Fräskopf**  
**Radial drilling and milling head**

**EWS** EWS Weigle GmbH & Co. KG  
 Maybachstr. 1  
 D-73066 Uhlingen  
 www.ews-tools.de

Technische Aenderungen vorbehalten!  
 Subject to technical modifications!  
 IDENT: DEWS048525

Nr. - No.  
**60.5525VL4IKIMTKW66**

REV: -/C  
 MNR.  
**205518**

