

Bei gleichzeitiger Verwendung halbiert sich das zulässige Drehmoment je Werkzeugspindel.  
The permissible torque is halved if both tool spindles are used simultaneously.

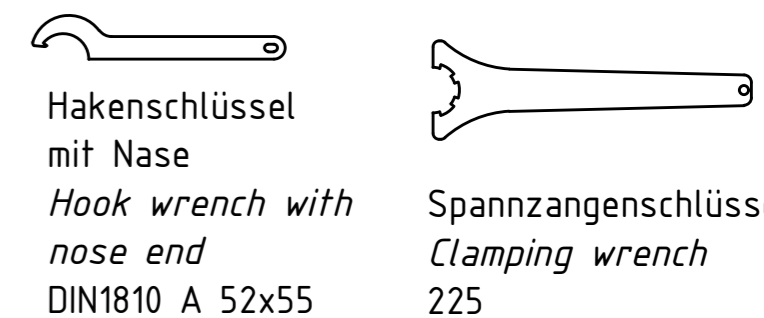
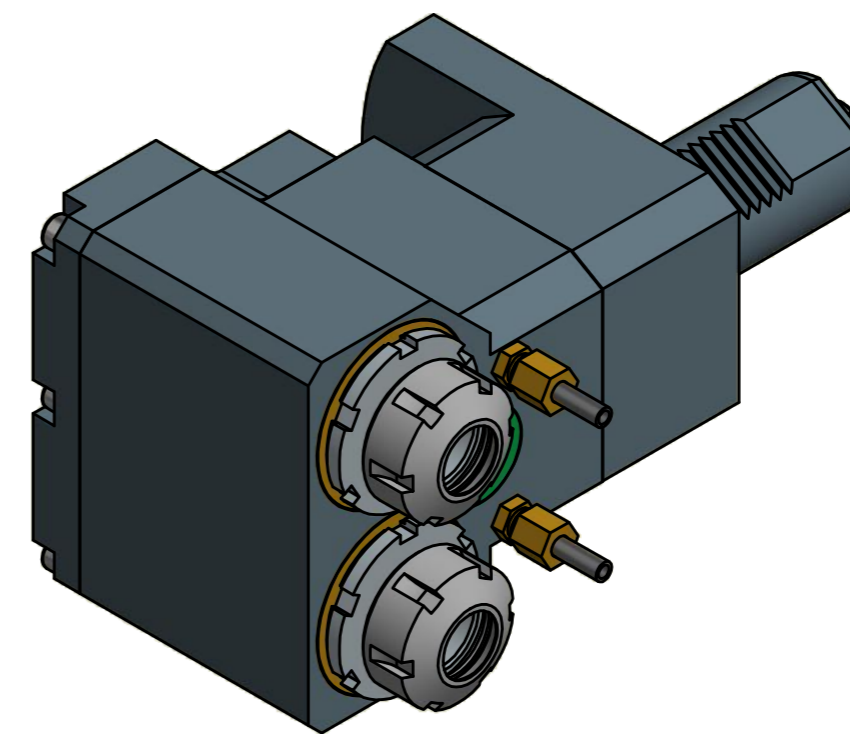
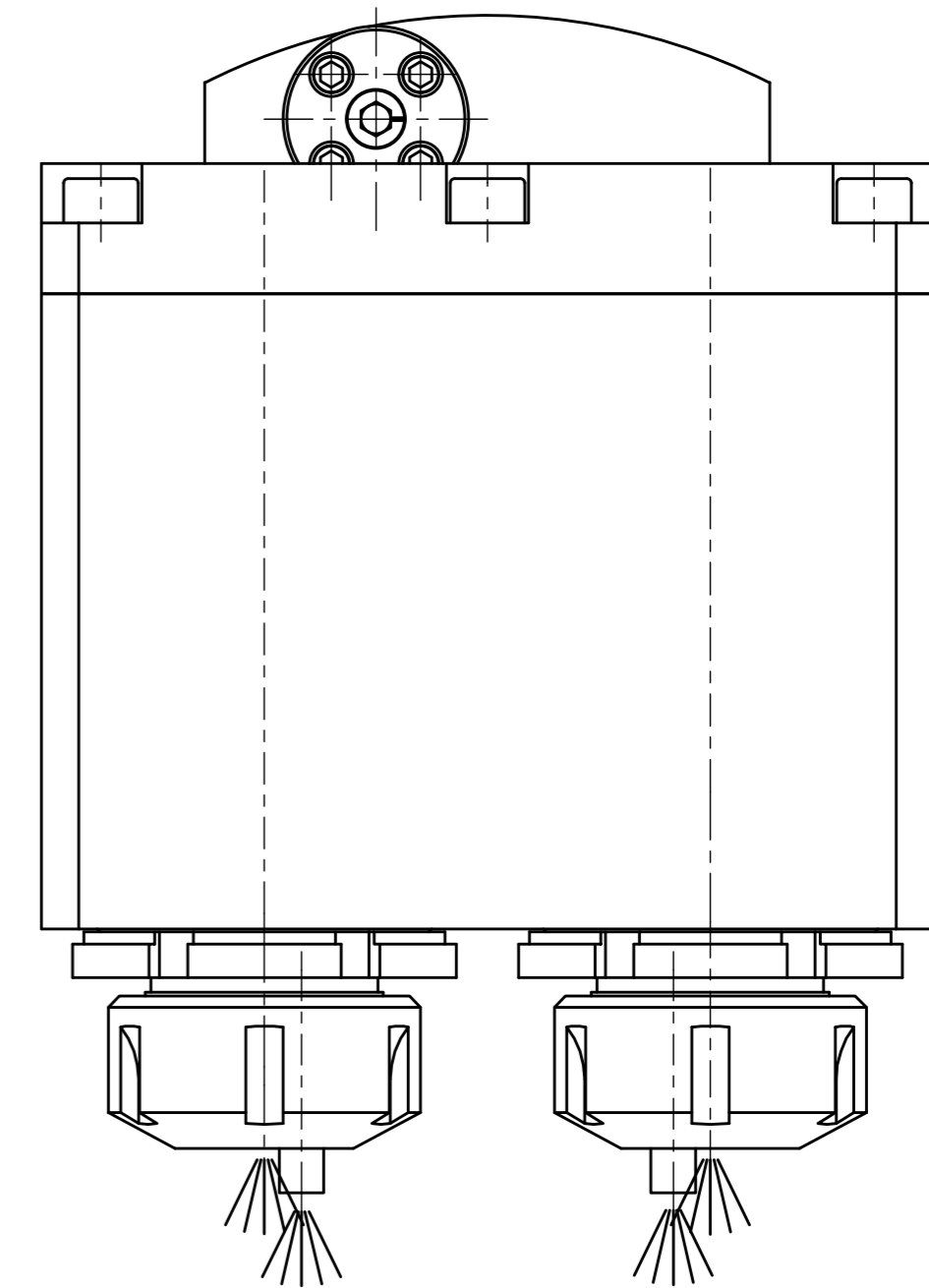

Copyright EWS Tool Technologies  
Weitergabe und Vervielfältigung dieser Unterlage, Verwertung und Mitteilung ihres Inhalts nicht gestattet, soweit nicht ausdrücklich zugestanden. Zuwiderhandlungen verpflichten zu Schadenersatz.

<p>Bemerkung - Note Für Trockenlauf geeignet! Use without coolant fluid allowed!</p>	<p>Technische Daten - technical data Weight = 10.514 [kg] Torque max. (M1/M2) = 25 / 25 [Nm] Speed max. (n1/n2) = 6000 / 6000 [1/min] Gear ratio (i)=n1:n2 = 1:1 Pressure (pmax) = 70 [bar]</p>	<p>Benennung - Title Radial Bohr und Fräskopf Radial drilling and milling head</p>	<p>EWS Tool Technologies EWS Weigle GmbH &amp; Co. KG Maybachstr. 1 D-73066 Uhlingen www.ews-tools.de</p> <p>Technische Änderungen vorbehalten! Subject to technical modifications! IDENT: DEWS052508 REV: -/B MNR. 178477</p> <p>60.4025DYSQT15RIKDTK60</p> <p>QR</p>
--	---	--	--