

Spannzange / collet ER25 DIN6499
Spannbereich / clamping range: 1,0 - 16,0

Gewindebohrzange / tapping collet
ET-1-25 M3-M10

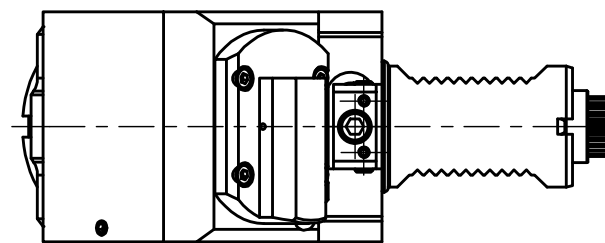

Doppelverzahnung Lizenz Traub
double tooth system licence Traub

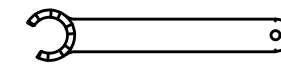
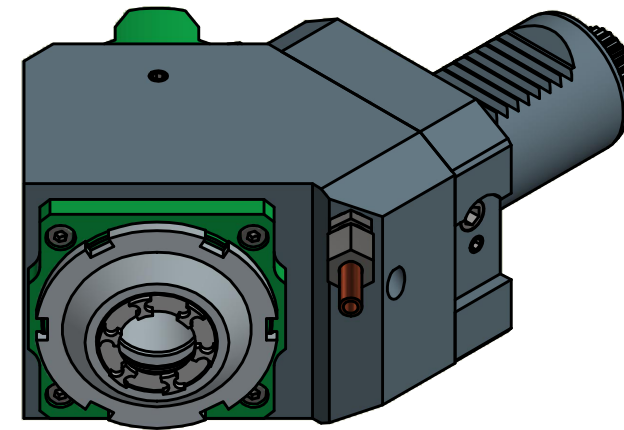

Spannzangenschlüssel für
innenliegende Mutter
Clamping wrench for
internal collet
225AX

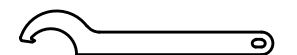

Hakenschlüssel
mit Nase
Hook wrench with
nose end
DIN1810 A 68x75

Copyright **EWS Tool Technologies**
Weitergabe und Vervielfältigung dieser Unterlage,
Verwertung und Mitteilung ihres Inhalts nicht
gestattet, soweit nicht ausdrücklich zugestanden.
Zu widerhandlungen verpflichtet zu Schadenersatz.

Bemerkung - Note

Technische Daten - technical data	
Weight	= 5.095 [kg]
Torque max. (M1/M2)	= 24 / 12 [Nm]
Speed max. (n1/n2)	= 6000 / 12000 [1/min]
Gear ratio (i)=n1:n2	= 1:2

Benennung - Title	
Radial Bohr und Fräskopf	
<i>Radial drilling and milling head</i>	

EWS Tool Technologies	EWS Weigle GmbH & Co. KG Maybachstr. 1 D-73066 UHINGEN www.ews-tools.de
Nr. - No.	60.4025CTXRL1TKW45IM

Technische Änderungen vorbehalten! Subject to technical modifications!	
IDENT: DEWS030309	REV: -/A
MNR.	
205115	

