

Spannzange / collet ER25 DIN6499  
Spannbereich / clamping range: 1,0 - 16,0

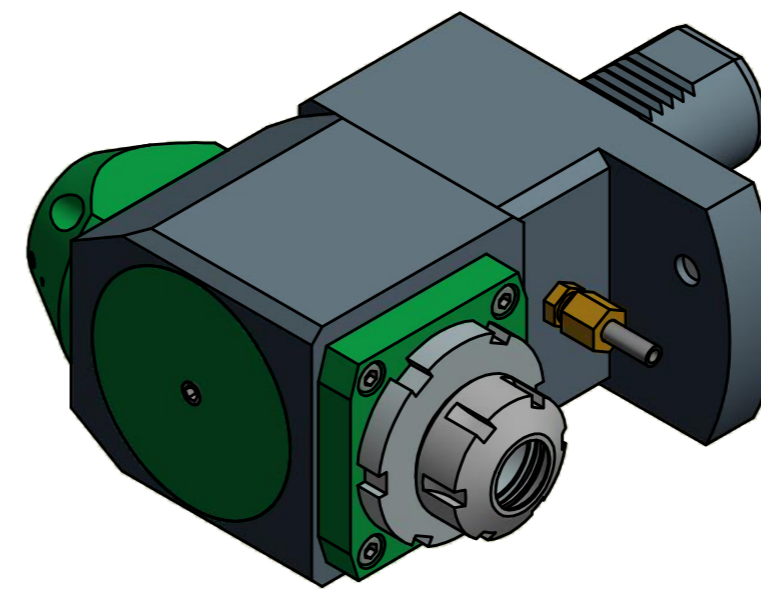

Hakenschlüssel  
mit Nase  
Hook wrench with  
nose end  
DIN1810 A 58x62

Spannzangenschlüssel  
Clamping wrench  
225

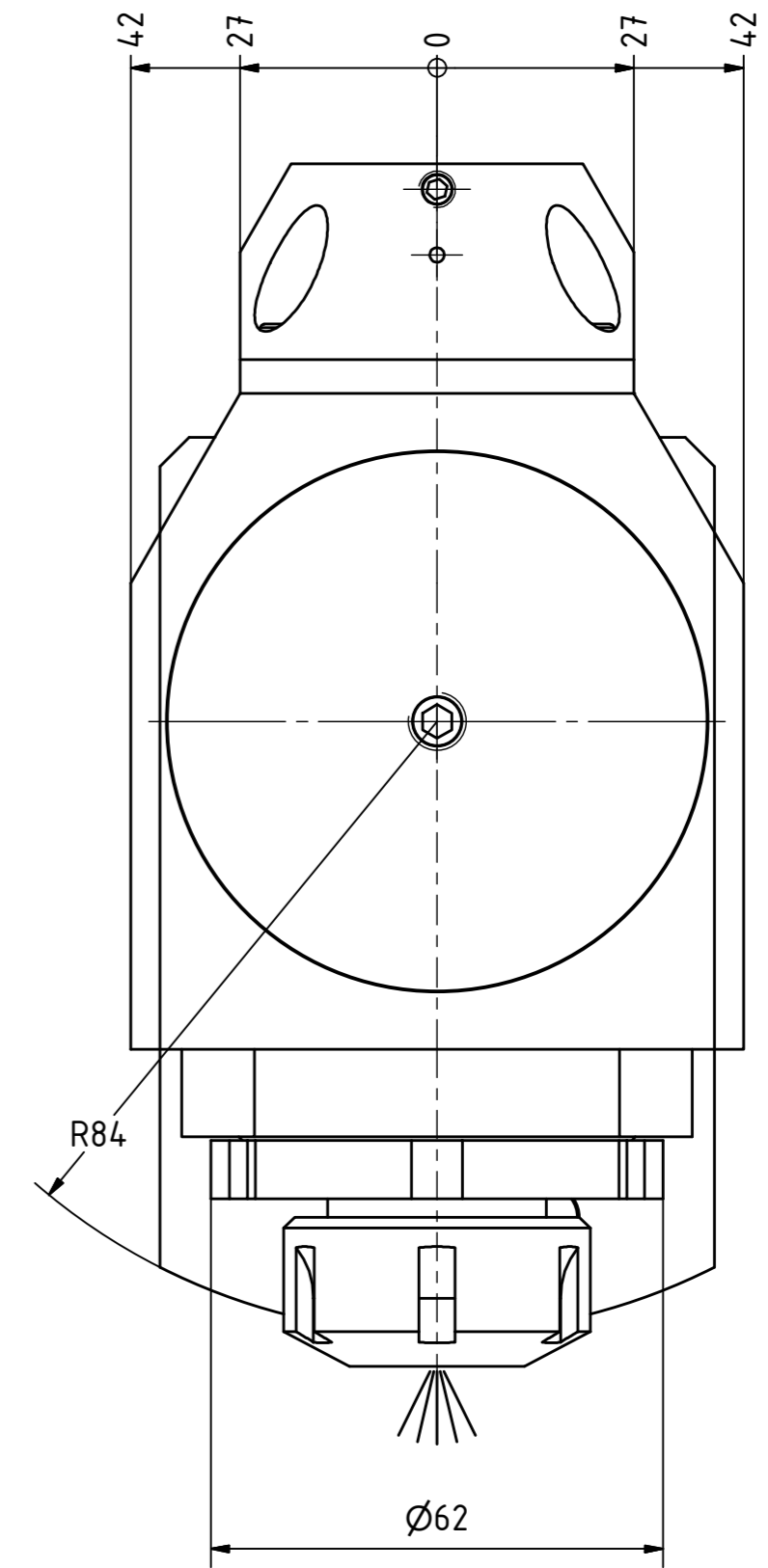
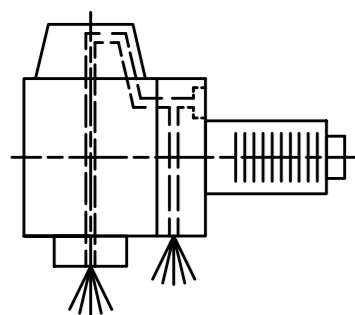

Innen- und Aussenkuehlung / Inside and outside coolant supply  
Kein Trockenlauf / No dry run  
Kuehlmittelfiltrierung<50µ / coolant filtration<50µ

Copyright **EWS Tool Technologies**  
Weitergabe und Vervielfaeltigung dieser Unterlage,  
Verwertung und Mitteilung ihres Inhalts nicht  
gestattet, soweit nicht ausdrecklich zugestanden.  
Zuwiderhandlungen verpflichten zu Schadenersatz.

Bemerkung - Note	Technische Daten - technical data
Nicht ohne Kuehlmittel betreiben! Not for use without coolant-fluid!	Weight = 7.762 [kg] Torque max. (M1/M2) = 45 / 15 [Nm] Speed max. (n1/n2) = 5000 / 15000 [1/min] Gear ratio (i)=n1:n2 = 1:3 Pressure (pmax) = 70 [bar]

Benennung - Title  
**Radial Bohr und Fräskopf**  
Radial drilling and milling head

<b>EWS</b> Tool Technologies	EWS Weigle GmbH & Co. KG Maybachstr. 1 D-73066 Uhlingen www.ews-tool.de	Technische Aenderungen vorbehalten! Subject to technical modifications!	IDENT: DEWS033132	REV: -/A
Nr. - No.	60.4.025MP610RIK113X100	MNR.	178111	QR