

Fraeserwelle austaschbar
Spindle removable

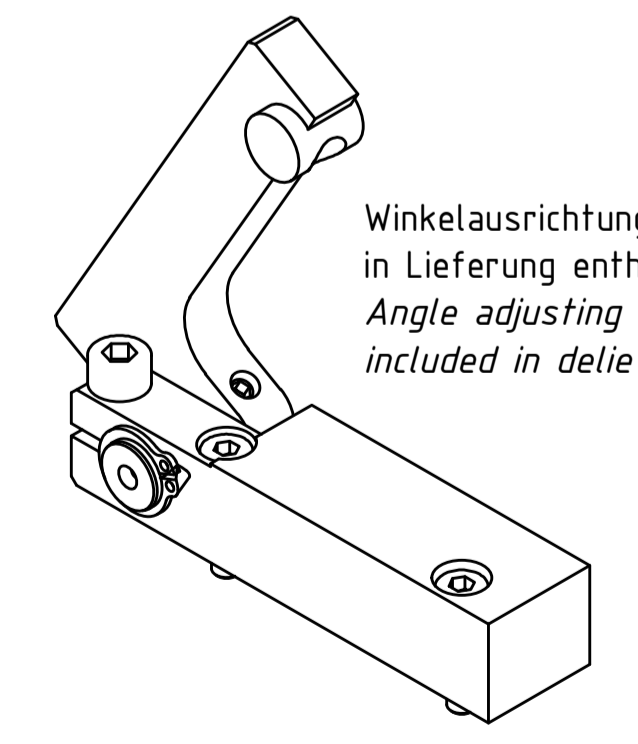
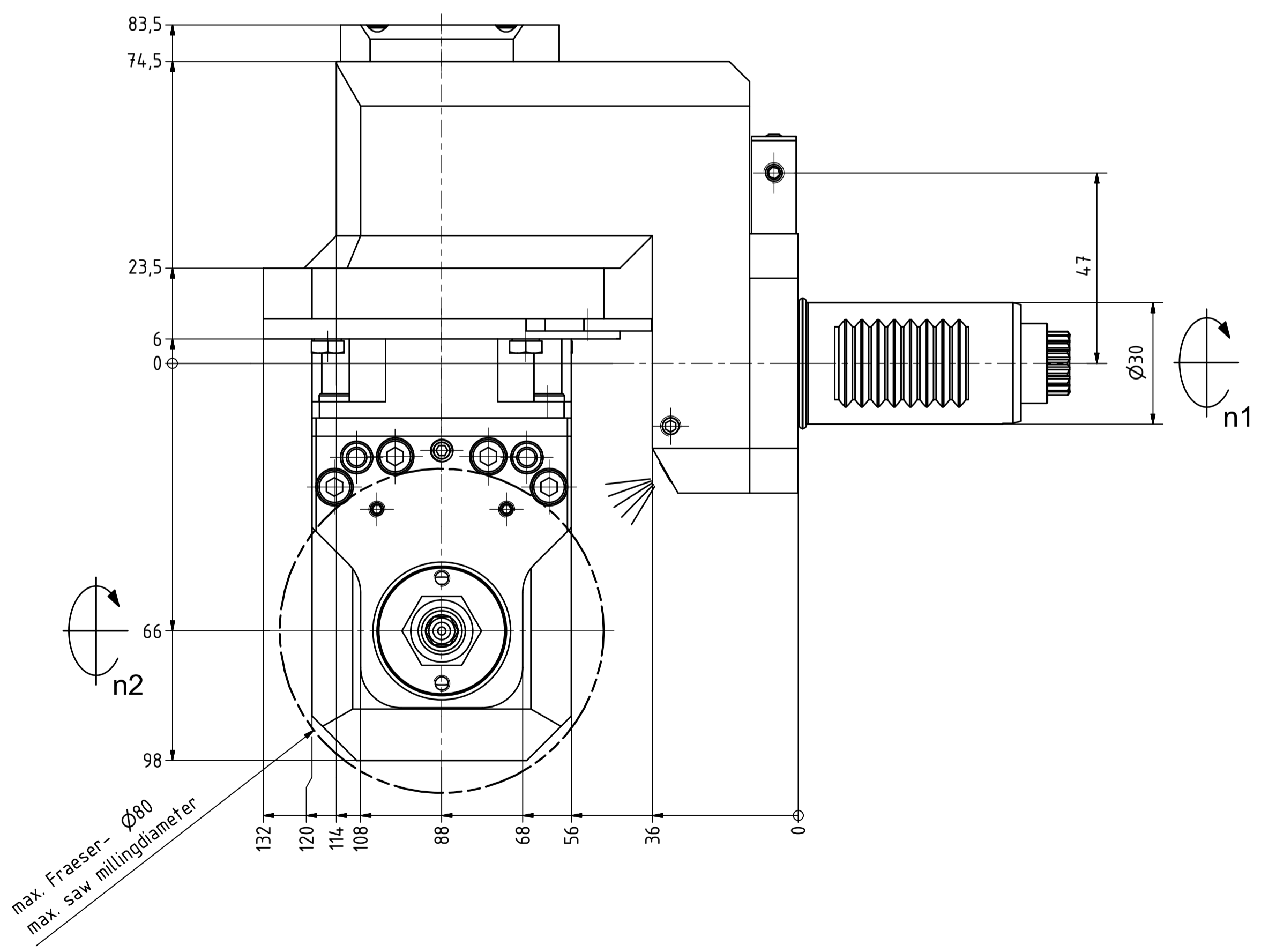
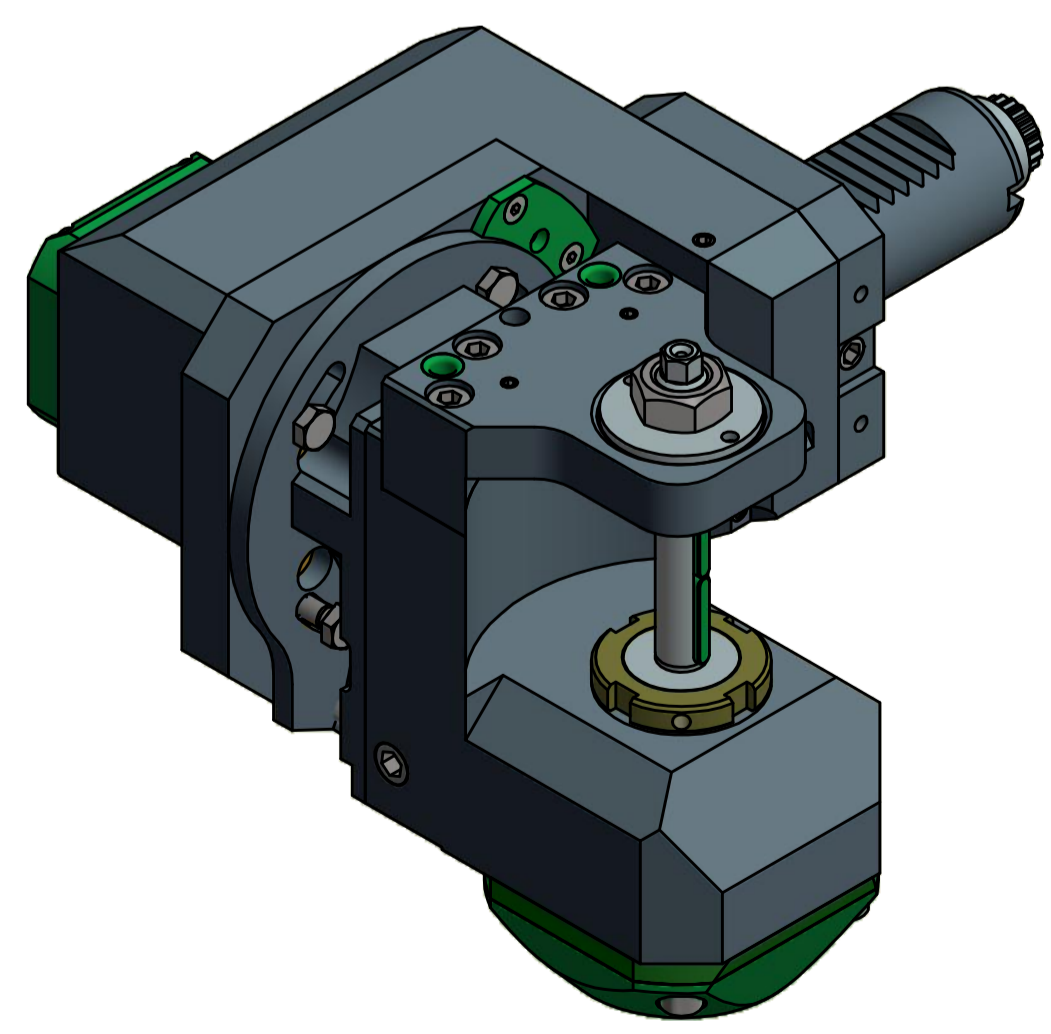
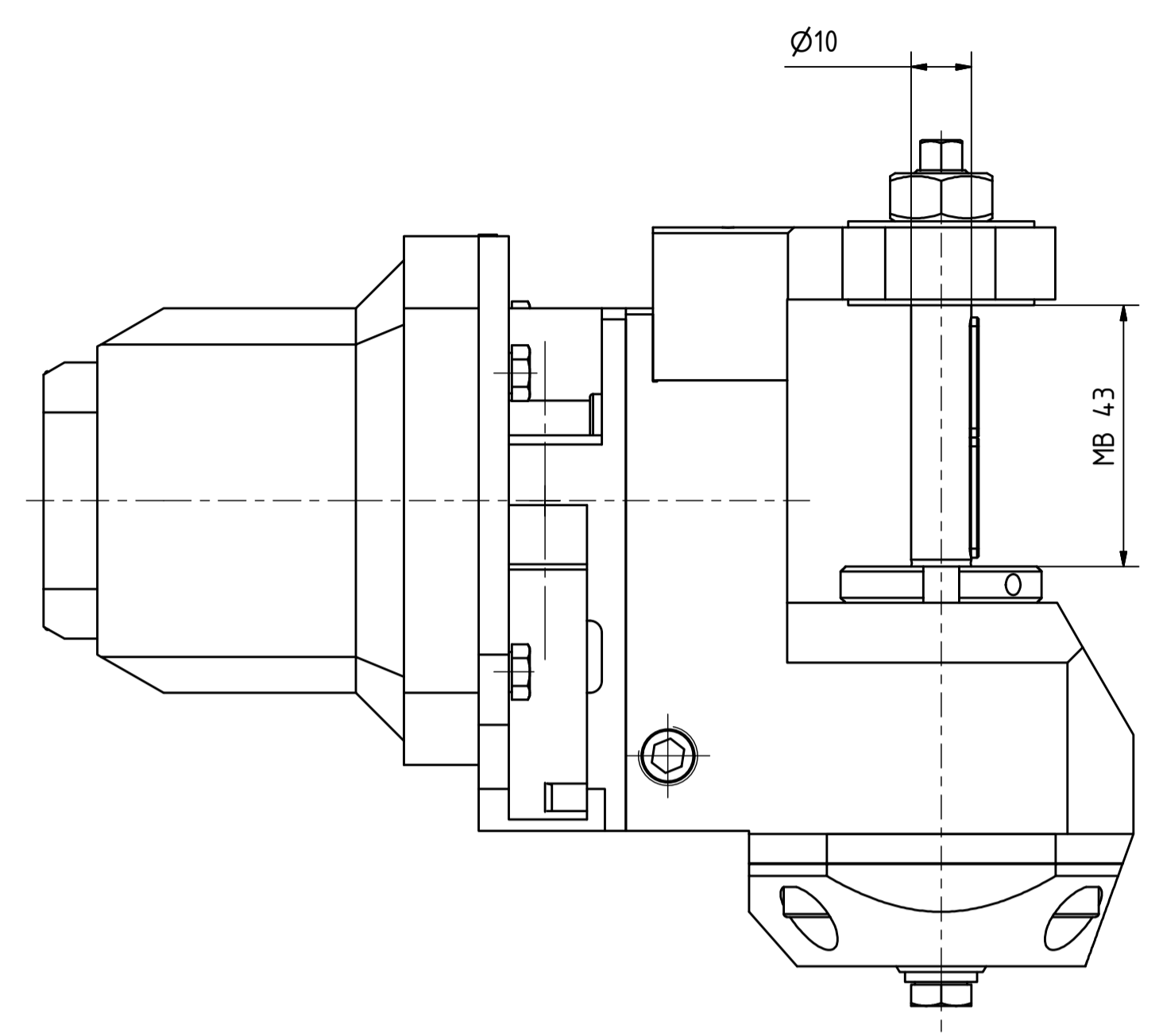
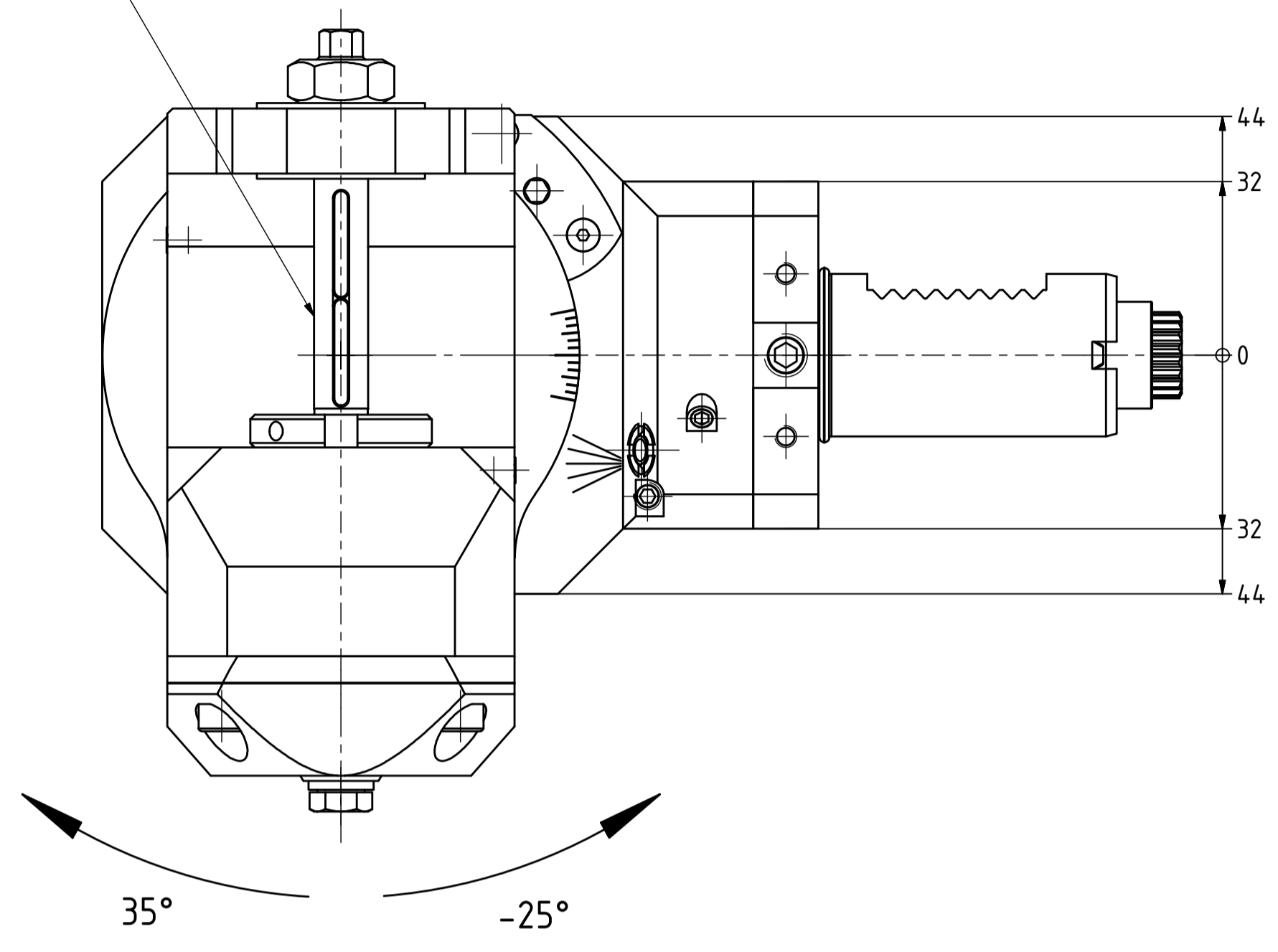

Winkelausrichtung & CD-ROM
in Lieferung enthalten!
Angle adjusting & CD-ROM
included in delivery!

Bemerkung - Note 	Technische Daten - technical data Weight = 7,799 [kg] Torque max. (M1/M2) = 20 / 60 [Nm] Speed max. (n1/n2) = 6000 / 2000 [1/min] Gear ratio (i)=n1:n2 = 3:1	Bemerkung - Note 	EWS Werkzeug GmbH & Co. KG Hauptstr. 1 42700 Solingen www.ews-tool.de Technische Änderungen vorbehalten! Subject to technical modifications! IDENT: DEWS036756 REV. -/A	QR 84.3010CTXRI3TKWMB43 206303
----------------------	--	----------------------	--	--------------------------------------

Copyright EWS Tool Technologies
Weitergabe und Vervielfältigung dieser Unterlage,
Verwertung und Mitteilung ihres Inhalts nicht
gestattet, soweit nicht ausdrücklich zugestanden.
Zuwendungen verpflichten zu Schadenersatz.