

Spannzange / collet ER32 DIN6499
Spannbereich / clamping range: 2,0 - 20,0

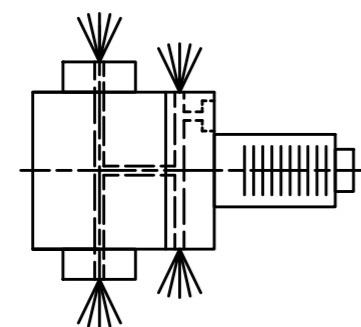
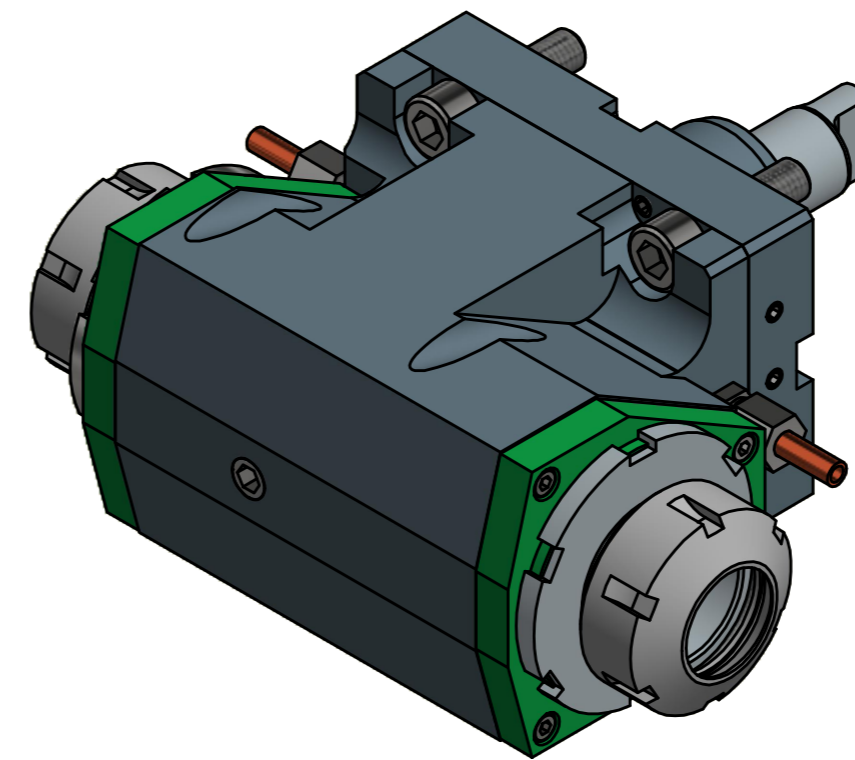
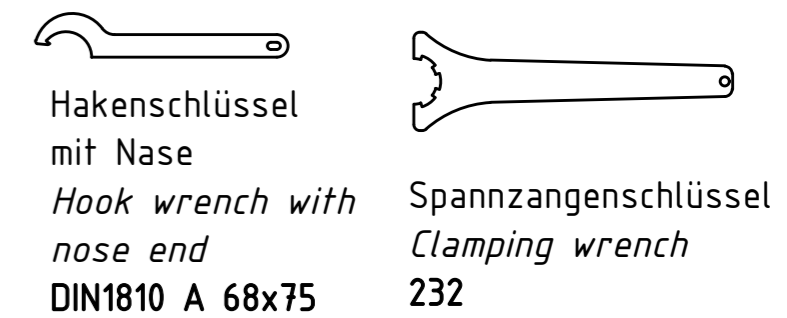
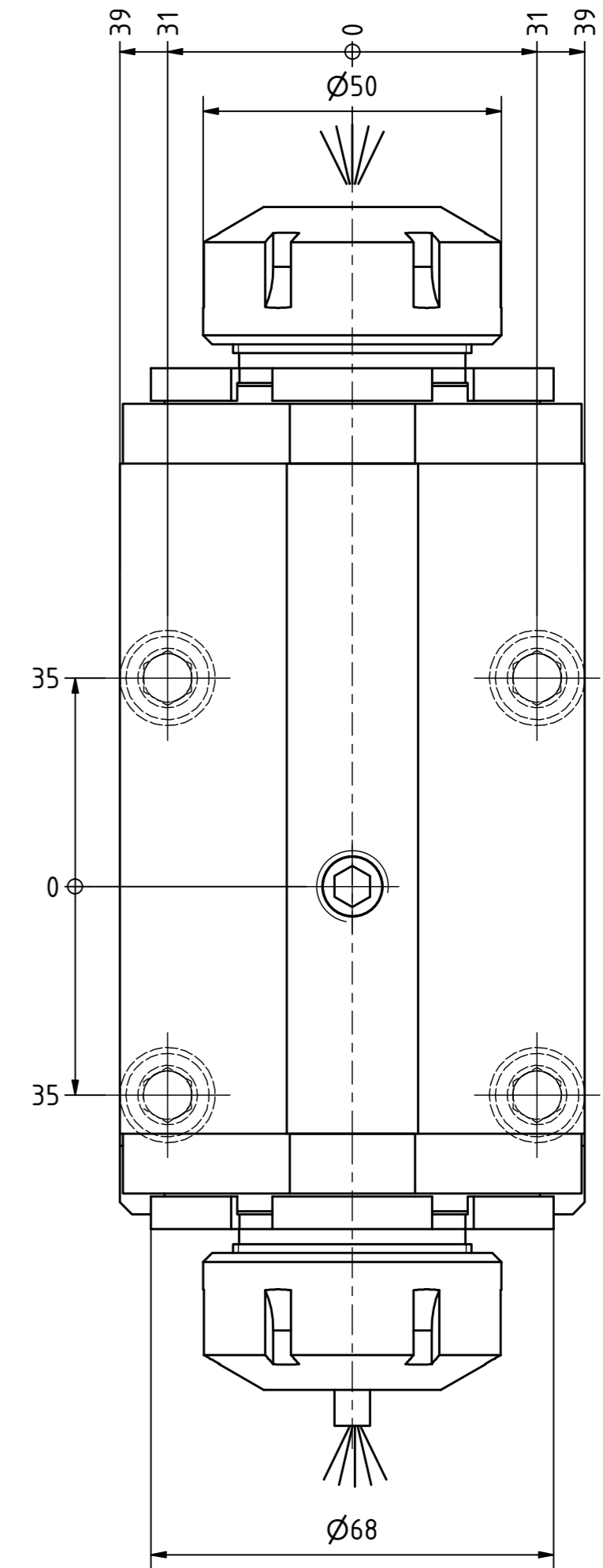

Innen- und Aussenkuehlung / Inside and outside coolant supply
Kein Trockenlauf / No dry run
Kuehlmittelfiltrierung=50µ / coolant filtration=50µ

Bemerkung - Note
Nicht ohne Kuehlmittel betreiben!
Not for use without coolant-fluid!

Technische Daten - technical data
Weight = 8.013 [kg]
Torque max. (M1/M2) = 32 / 32 | 32 [Nm]
Speed max. (n1/n2) = 10000 / 10000 | 10000 [1/min]
Gear ratio (i)=n1:n2 = 1:1 | 1:1
Pressure (pmax) = 70 [bar]

Benennung - Title
Radial Bohr und Fräskopf
Radial drilling and milling head

	<small>EWS Weigle GmbH & Co. KG Maybachstr. 1 D-73066 Uhlingen www.ews-tools.de</small>	<small>Technische Aenderungen vorbehalten! Subject to technical modifications!</small>	
		<small>IDENT: DEWS103604</small>	
<small>Nr. - No.</small> 60.4032DNZIKHSD10	<small>MNR.</small> 205198	<small>Copyright EWS Tool Technologies Weitergabe und Vervielfaeltigung dieser Unterlage, Verwertung und Mitteilung ihres Inhalts nicht gestattet, soweit nicht ausdrecklich zugestanden. Zuwaerhandlungen verpflichten zu Schadenersatz.</small>	