

Spannzange / collet ER25 DIN6499
Spannbereich / clamping range: 1,0 - 16,0

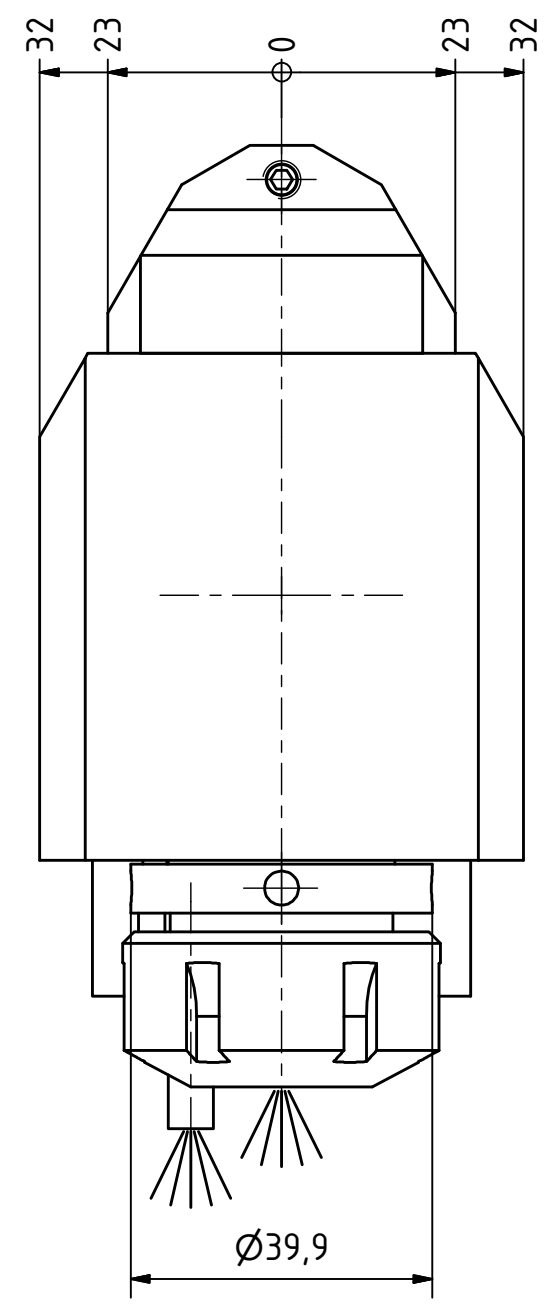

Spannzangenschlüssel
Clamping wrench
225

Hakenschlüssel
mit Zapfen
Hook wrench
with fixed pin
DIN1810 B 40x42

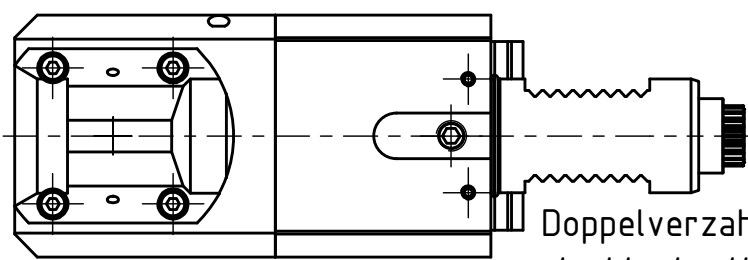
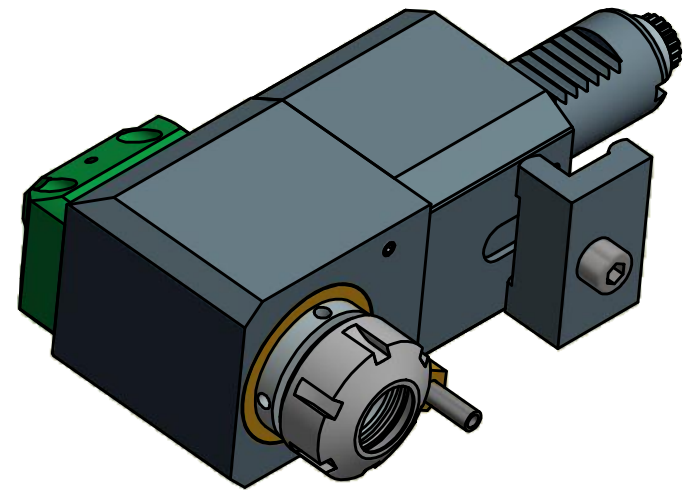

Doppelverzahnung Lizenz Traub
double tooth system licence Traub

Innen- und Aussenkuehlung / Inside and outside coolant supply
Kein Trockenlauf / No dry run
Kuehlmittelfiltrierung <math>< 50\mu</math> / coolant filtration <math>< 50\mu</math>

Copyright **EWS Tool Technologies**
Weitergabe und Vervielfaeltigung dieser Unterlage,
Verwertung und Mitteilung ihres Inhalts nicht
gestattet, soweit nicht ausdrecklich zugestanden.
Zuwiderhandlungen verpflichten zu Schadenersatz.

<p>Bemerkung - Note</p> <p>Nicht ohne Kuehlmittel betreiben! Not for use without coolant-fluid!</p>	<p>Technische Daten - technical data</p> <p>Weight = 4.290 [kg] Torque max. (M1/M2) = 25 / 25 [Nm] Speed max. (n1/n2) = 8000 / 8000 [1/min] Gear ratio (i)=n1:n2 = 1:1 Pressure (pmax) = 70 [bar]</p>	<p>Benennung - Title</p>	<p>EWS Tool Technologies</p> <p>EWS Weigele GmbH & Co. KG Maybachstr. 1 D-73066 Uehingen www.ews-tools.de</p>	<p>Technische Aenderungen vorbehalten! Subject to technical modifications!</p> <p>IDENT: DEWS032750</p>	<p>REV: -/A</p> <p>MNR.</p> <p>205664</p>
			<p>Nr. - No.</p> <p>60.3025LCTXRLIKOT02</p>	<p>QR</p>	