

Fraeserwelle austauschbar  
Spindle removable

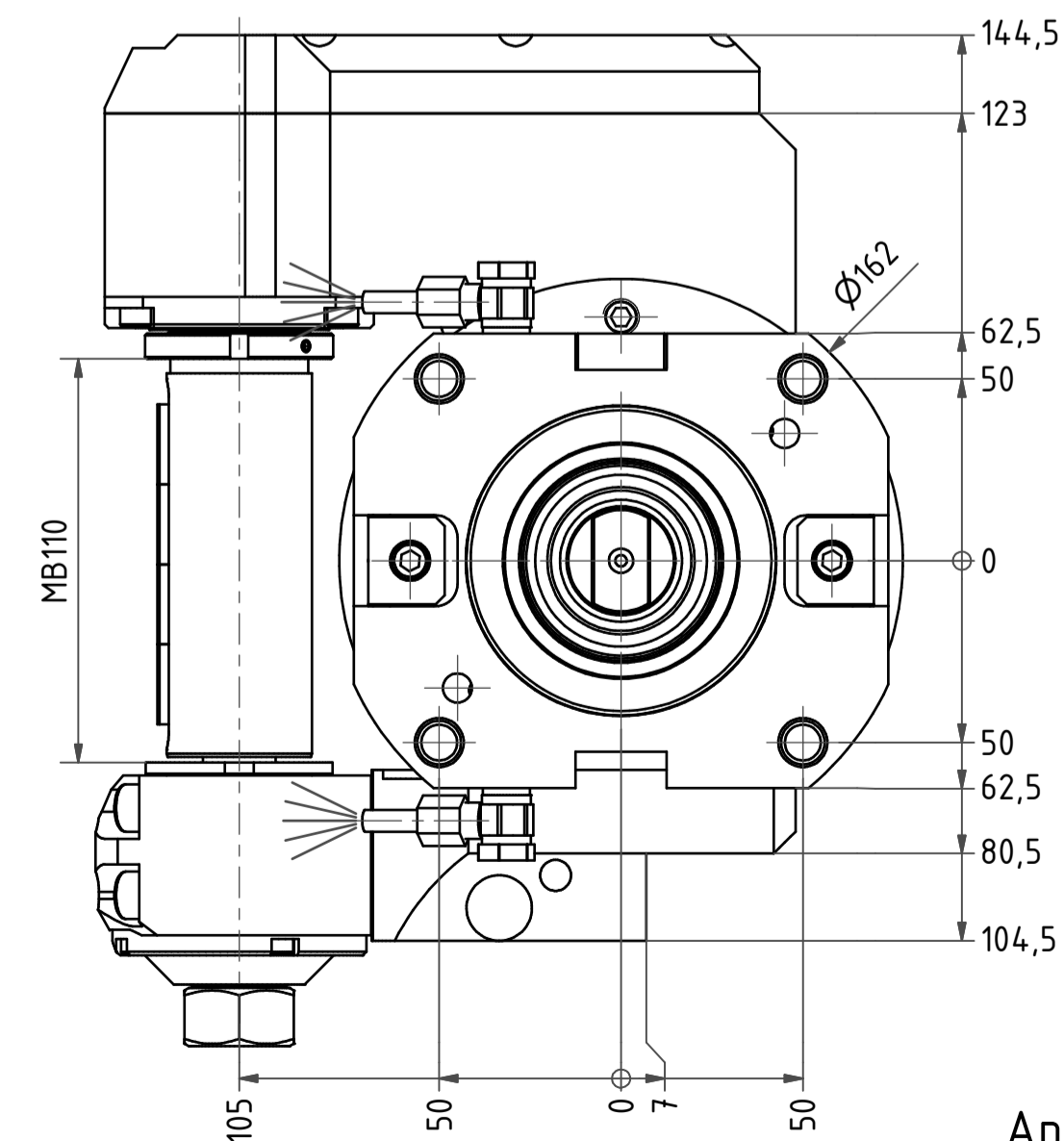
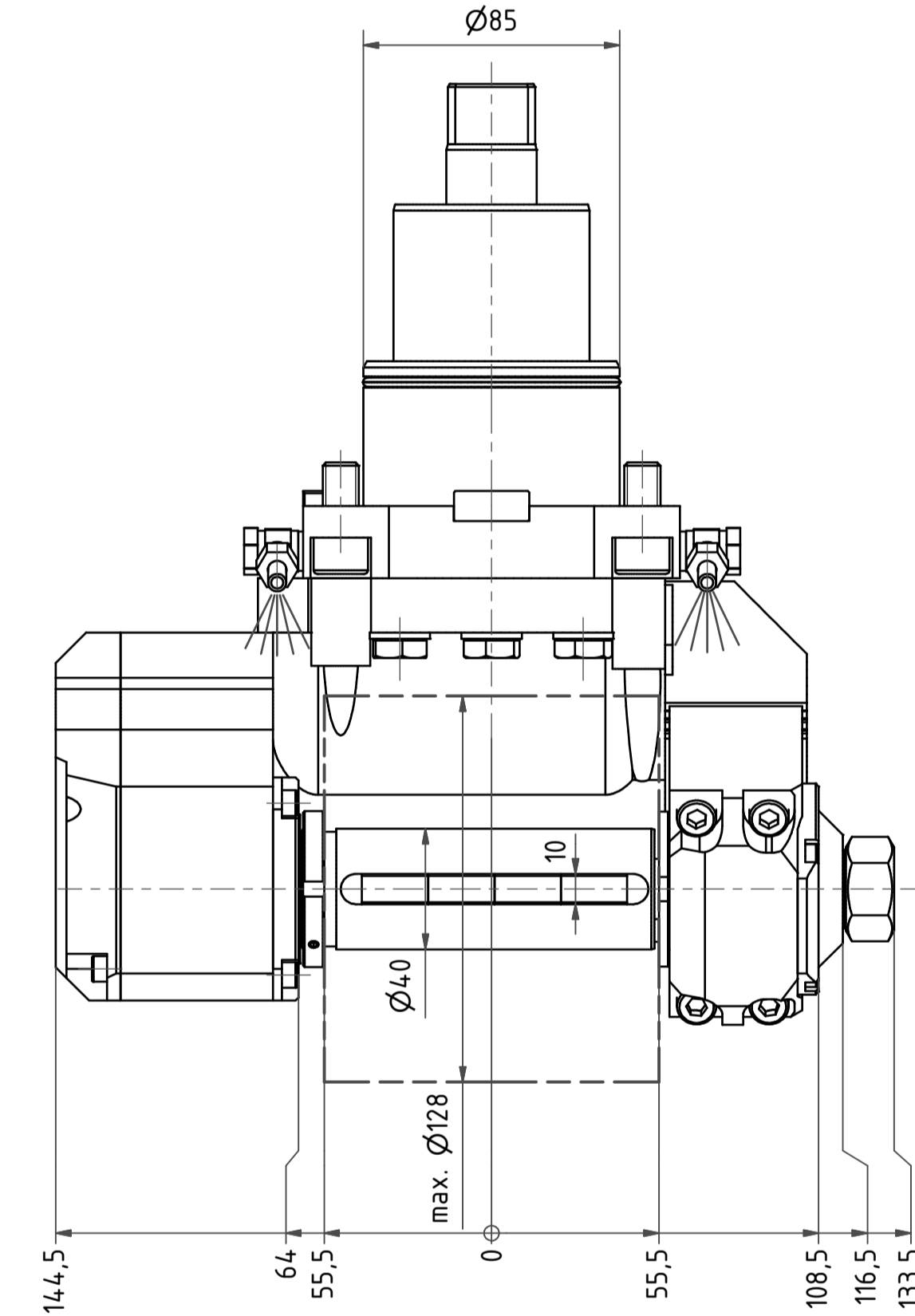
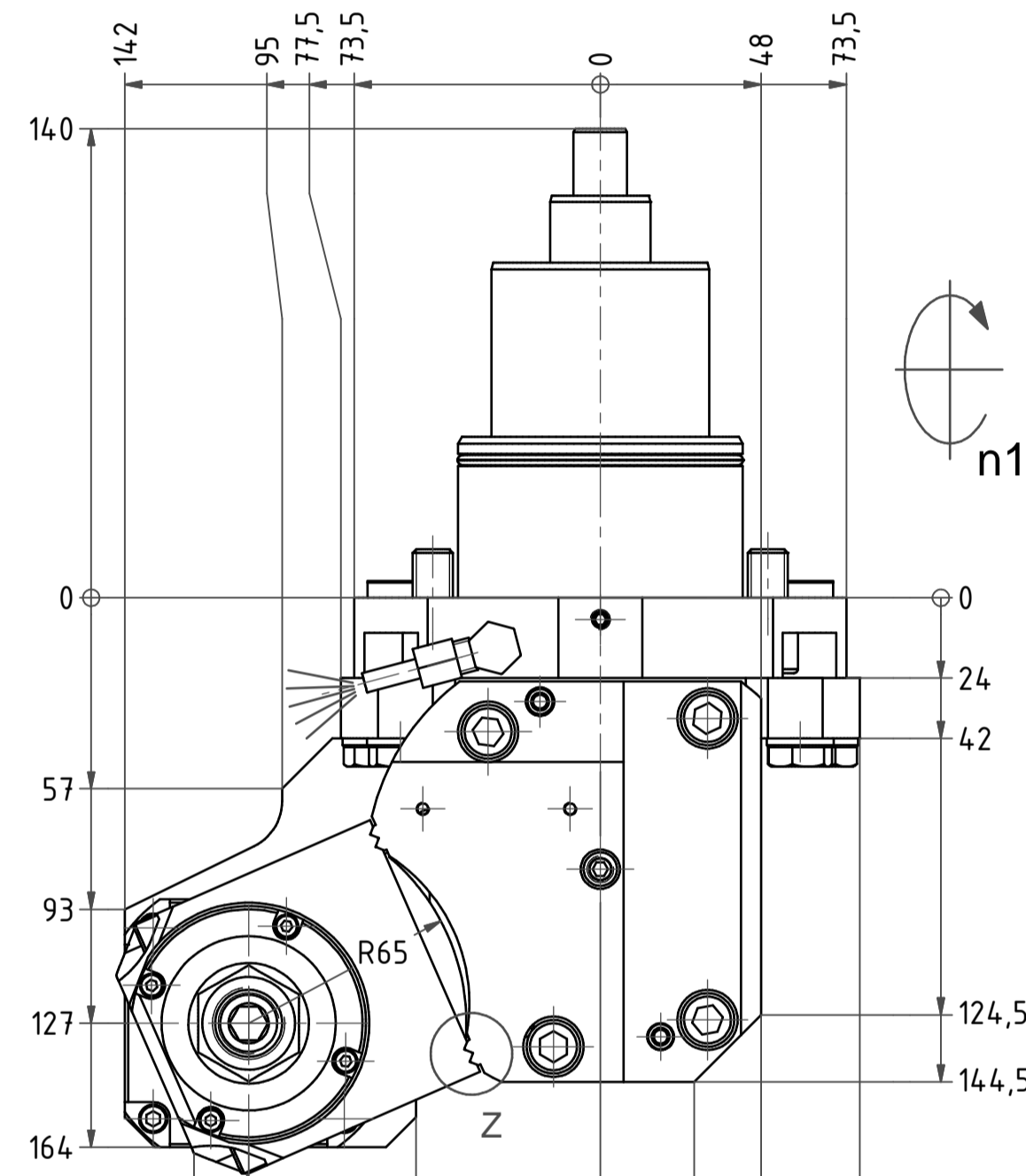
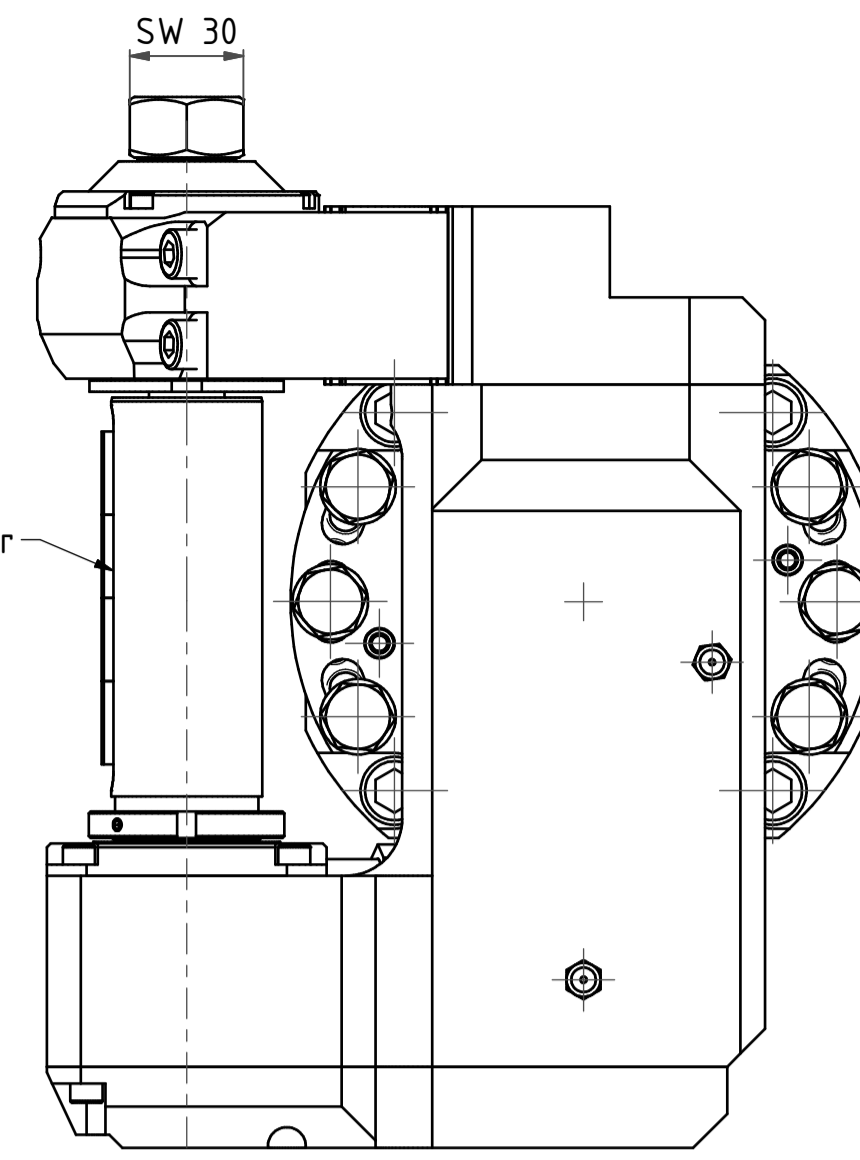

Ansichten 1:2

Gewicht: 28 kg  
Weight: 28 kg

Beide Nachbarstationen nicht verwendbar!  
Both neighbour stations are not useable!

Bemerkung - Note  
mit Kegelrollenlagern  
with taper roller bearings

Technische Daten - Technical data  
M1 / M2 = 80 / 160 Nm  
n1 / n2 = 4000 / 2000 1/min  
i (N1:N2) = 2:1

Bemerkung - Note  
Scheibenfräserkopf  
Radial saw milling head

name	date	Technische Änderungen vorbehalten! Subject to technical modifications!
signature	12.11.2014	
EWS EWS Werkzeug GmbH & Co. KG Hauptstraße 7 D-75098 Ohligsen Tel. +49(0)714120544-100		64.854.0S180912Z105MB110 DIN A1
MNR: 178308	IDENT: D-EWS-167476	Blaatt - page 1 (1)

Copyright EWS Tool Technologies  
Weitergabe und Vervielfältigung dieser Unterlage,  
Verwertung und Mitteilung ihres Inhalts nicht  
gestattet, soweit nicht ausdrücklich zugestanden.  
Zuwerhandlungen verpflichten zu Schadenersatz.