

Spannzange / collet ER20 DIN6499
 Spannbereich / clamping range: 1,0 - 13,0

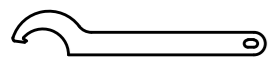

Hakenschlüssel
 mit Nase
 Hook wrench with
 nose end
 DIN1810 A 40x42

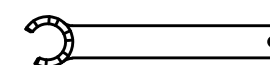

Spannzangenschlüssel für
 innenliegende Mutter
 Clamping wrench for
 internal collet
 220AX

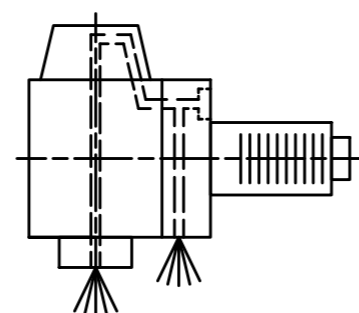

Innen- und Aussenkuehlung / Inside and outside coolant supply
 Kein Trockenlauf / No dry run
 Kuehlmittelfiltrierung-50µ / coolant filtration-50µ

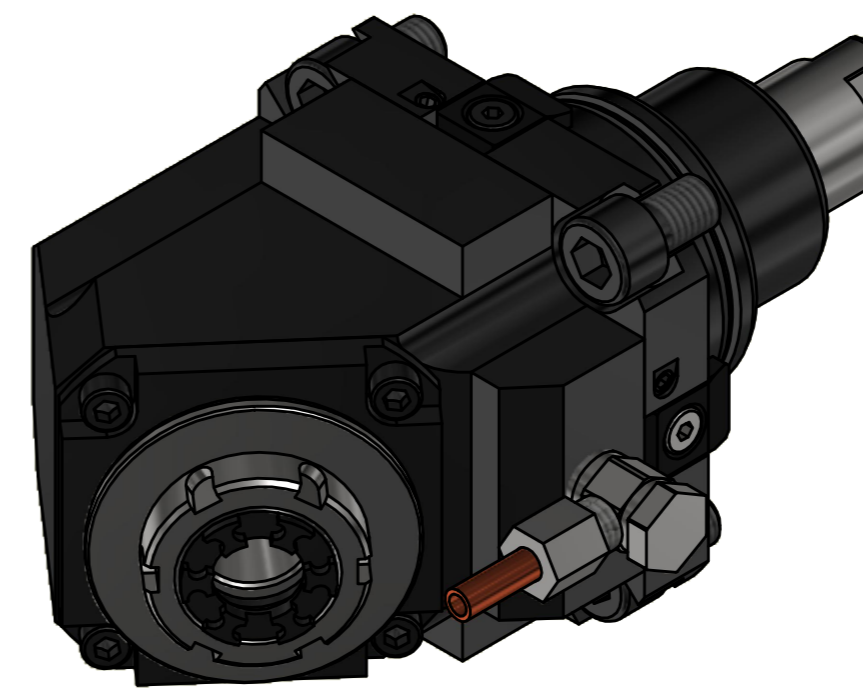

Benennung - Title	Technische Daten - technical data
Nicht ohne Kuehlmittel betreiben! Not for use without coolant-fluid!	Weight = 3.763 [kg] Torque max. (M1/M2) = 16 / 16 [Nm] Speed max. (n1/n2) = 6000 / 6000 [1/min] Gear ratio (i)=n1:n2 = 1:1 Pressure (pmax) = 70 [bar]

Benennung - Title
Radial Bohr und Fräskopf
Radial drilling and milling head

 EWS Weigle GmbH & Co. KG Maybachstr. 1 D-73066 Uhlingen www.ews-tool.de	Technische Aenderungen vorbehalten! Subject to technical modifications! IDENT: DEWS030177	 MNR REV: -/B
	Nr. - No. 60.5520VL2IKTKW49IM	204702



Copyright **EWS Tool Technologies**
 Weitergabe und Vervielfaeltigung dieser Unterlage,
 Verwertung und Mitteilung ihres Inhalts nicht
 gestattet, soweit nicht ausdruecklich zugestanden.
 Zuwiderhandlungen verpflichten zu Schadenersatz.