

Winkelausrichtung & CD-ROM
in Lieferung enthalten!
Angle adjusting & CD-ROM
included in delivery!

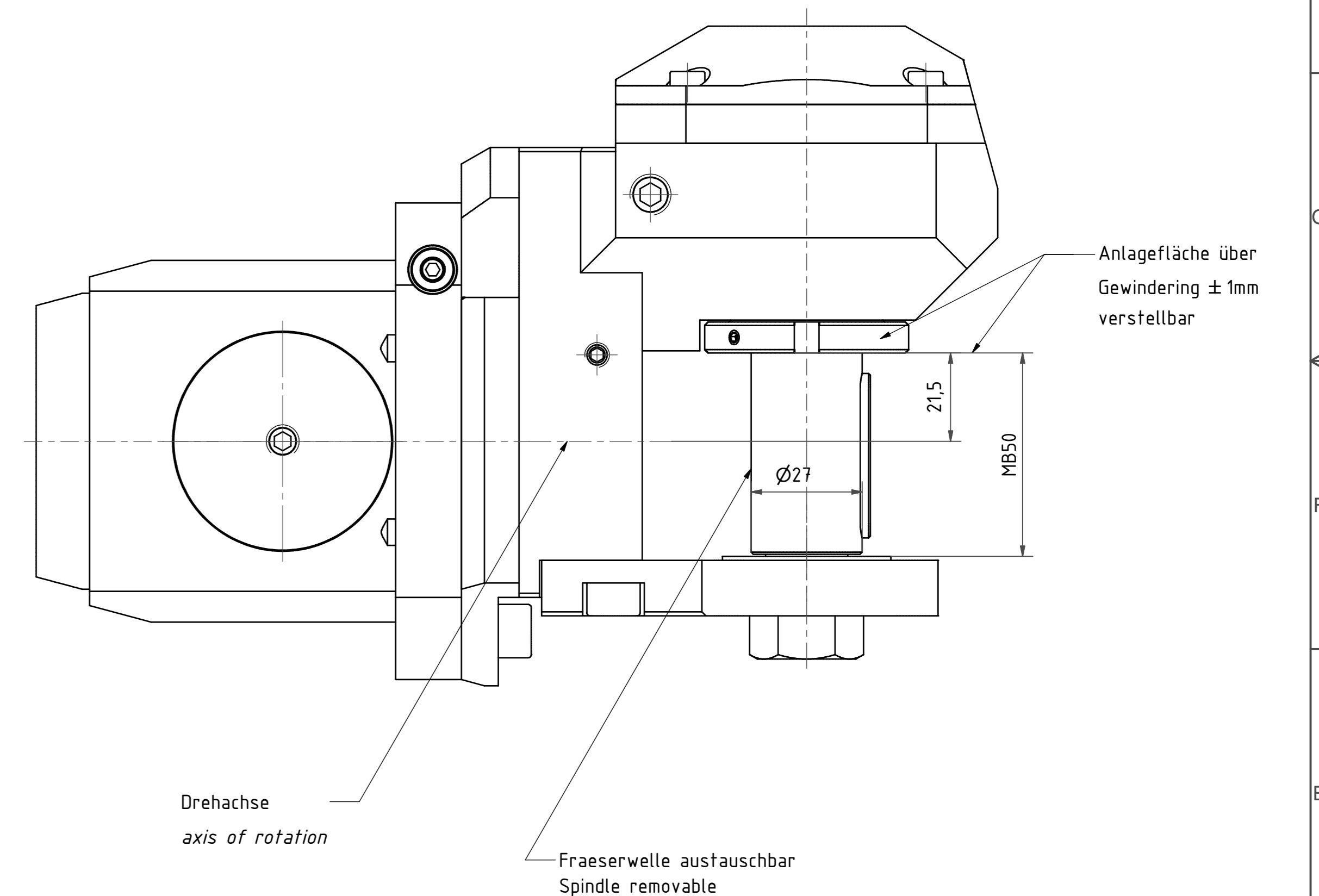
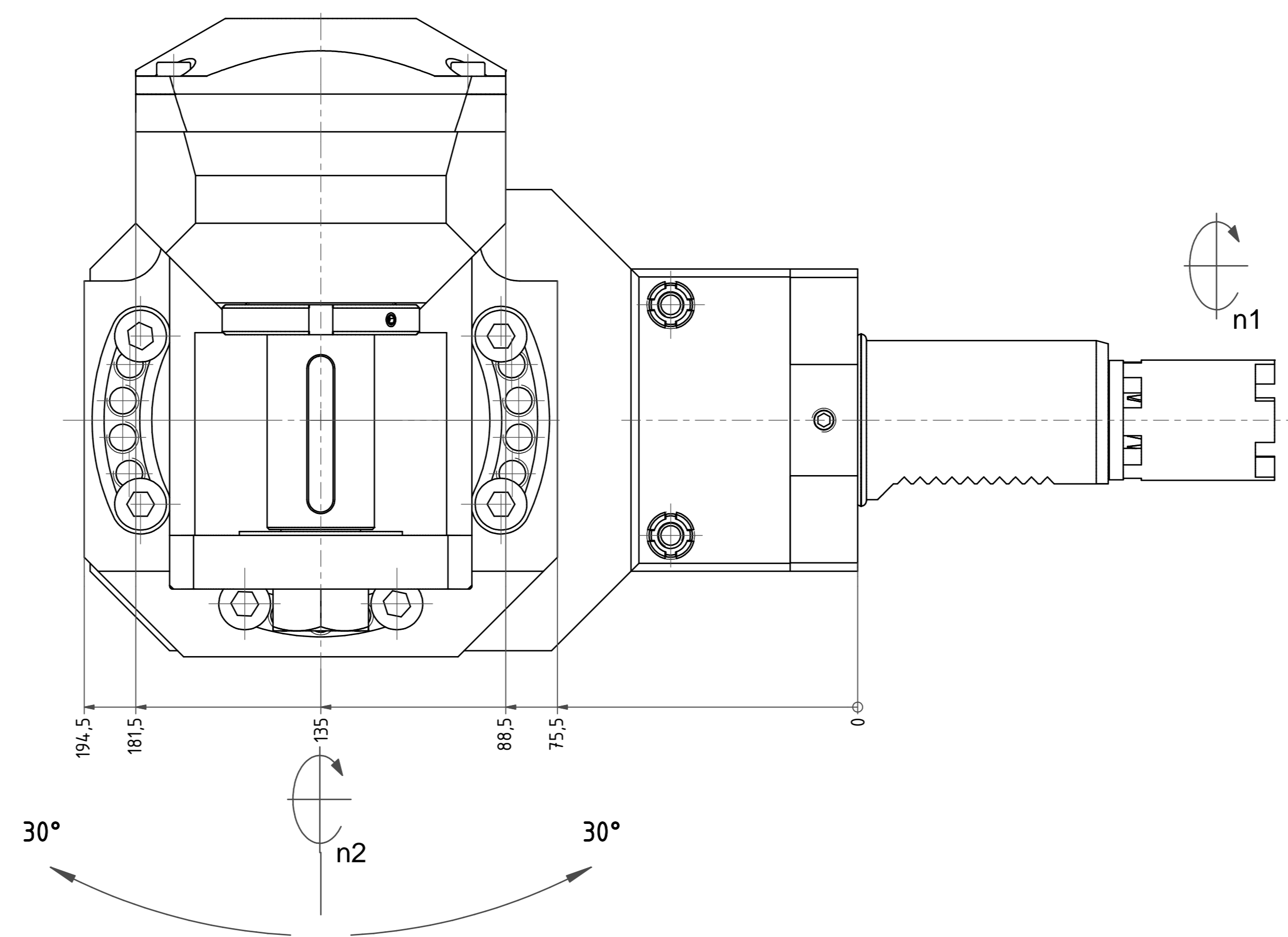
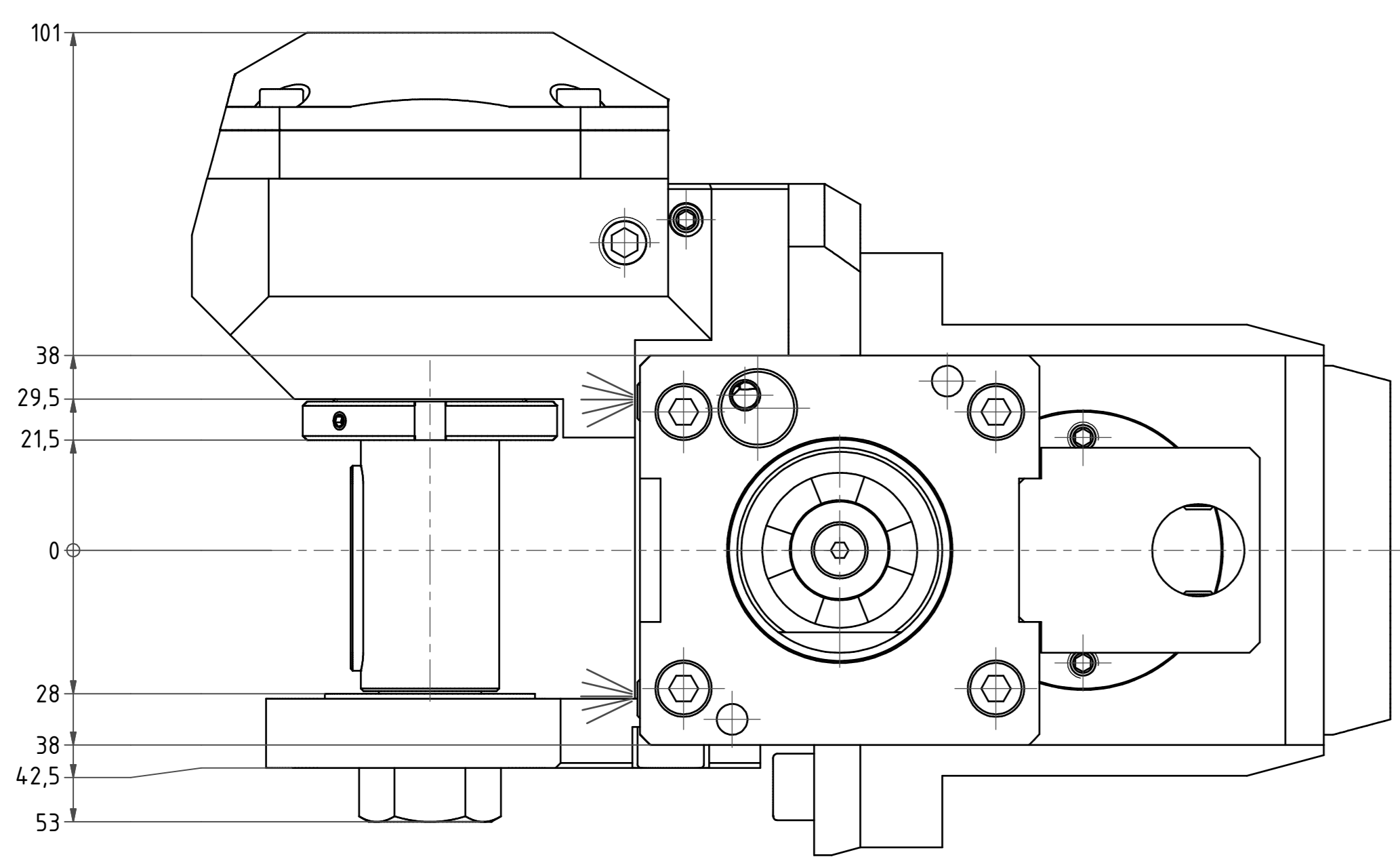

Zwei Nachbarstationen könnten entfallen!!
Two neighbour stations might be not useable!!

Copyright EWS Tool Technologies
Wiederverbreitung dieser Unterlagen
Verwertung und Mitteilung ihres Inhalts nicht
gestattet, soweit nicht ausdrücklich zugestanden.
Zusammenfassungen vorbehalten.

Technische Daten - Technical data M1 / M2 = 50 / 150 Nm n1 / n2 = 6000 / 2000 1/min i (n1/n2) = 3:1	Radial Scheibenfräserkopf versetzt Saw milling spindle offset	name: 84.4022HAASSL20L3TKW date: 21.10.2016 subject: for technical modifications!	DIN A0 Blatt - page 1 (1)
--	--	---	------------------------------