

Doppelverzahnung Lizenz Traub
double tooth system licence Traub

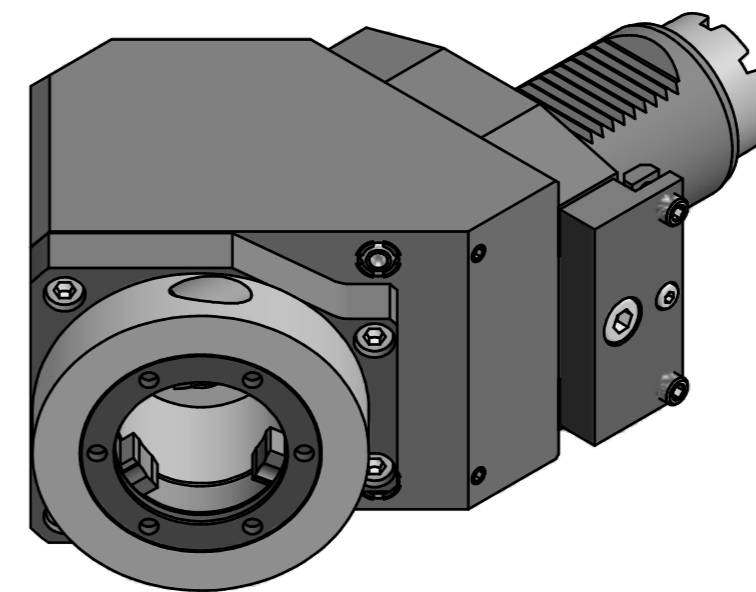

Copyright **EWS Tool Technologies**
Weitergabe und Vervielfältigung dieser Unterlage,
Verwertung und Mitteilung ihres Inhalts nicht
gestattet, soweit nicht ausdrücklich zugestanden.
Zuwerhandlungen verpflichten zu Schadenersatz.

Bemerkung - Note	Technische Daten - technical data		Benennung - Title	 EWS <small>EWS Weigete GmbH & Co. KG Maybachstr. 1 D-72096 Uhingen Tel. +49(0)7161/93040-100</small>	Technische Änderungen vorbehalten! Subject to technical modifications! Nr. 60.50V5TOEMRLAPTkw45 MNR: 177024 IDENT: D-EWS-167614 - Blatt - page 1 (1)	 DIN A2
	$M_1 / M_2 = 100 / 100 \text{ Nm}$ $n_1 / n_2 = 4000 / 4000 \text{ 1/min}$ $i (N_1:N_2) = 1:1$	Radial Bohr und Fräskopf <i>Radial drilling and milling head</i>				