

Ceramic Seal

Highspeed

Tech Details

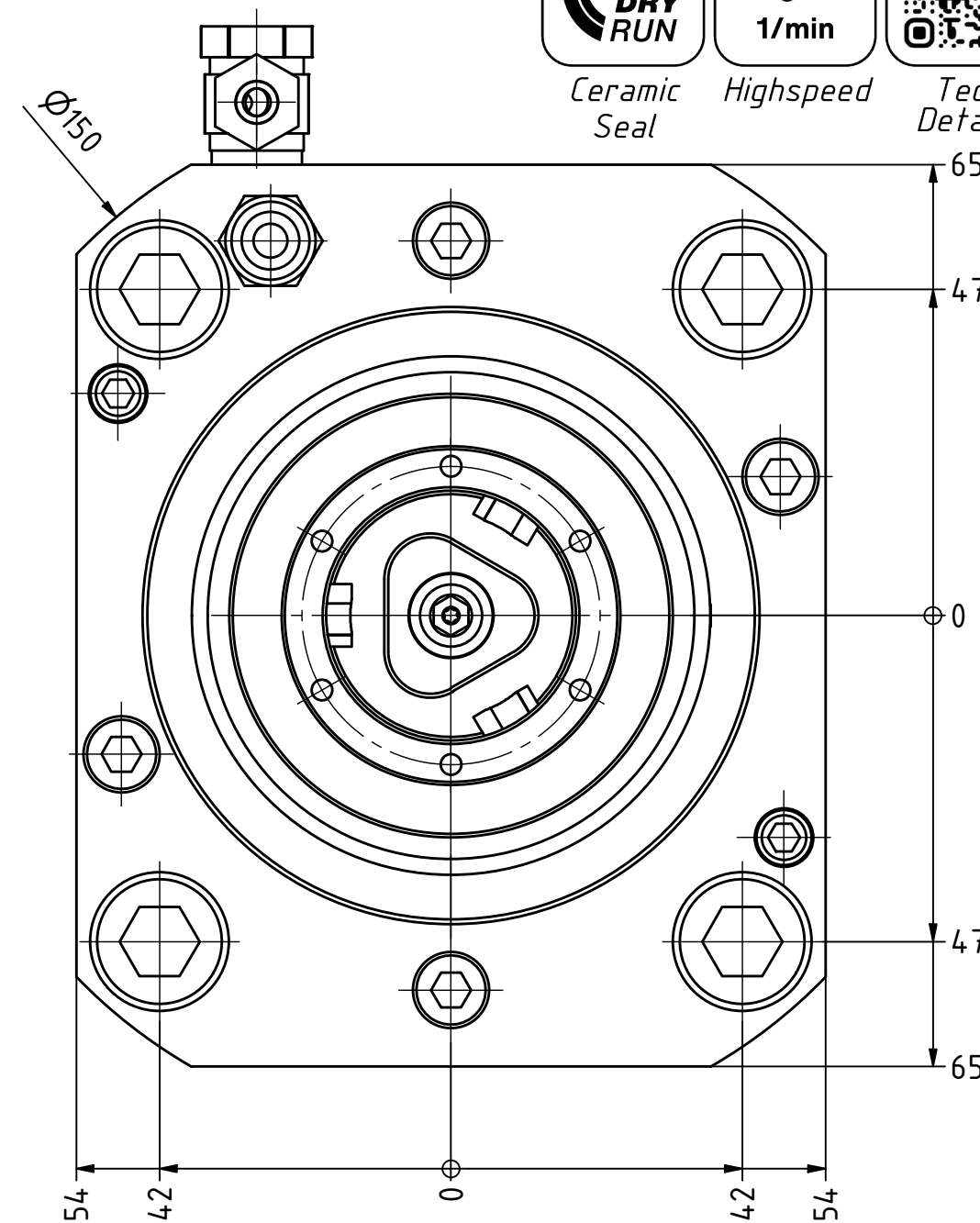
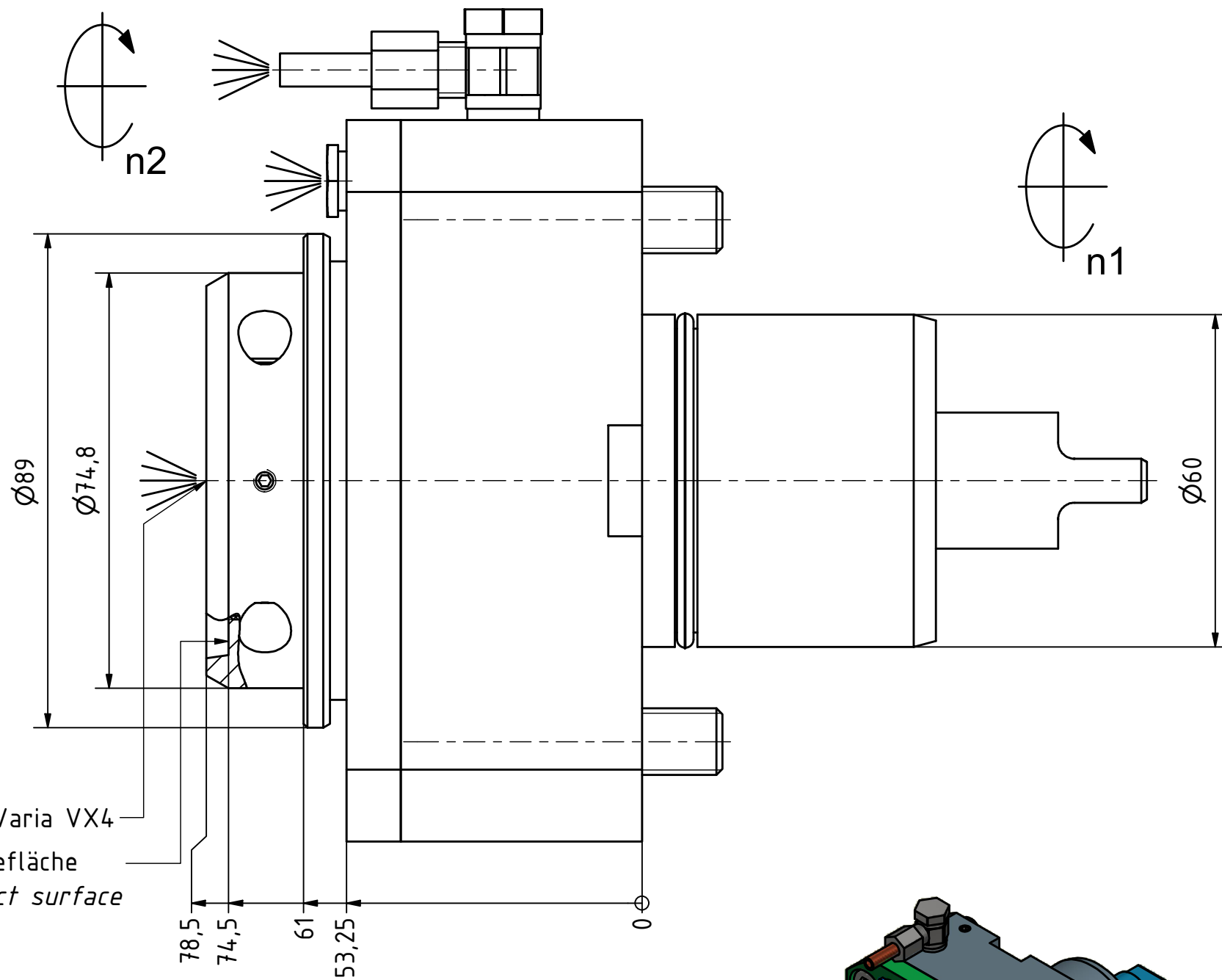

EWS-Varia VX4  
Anlagefläche  
contact surface

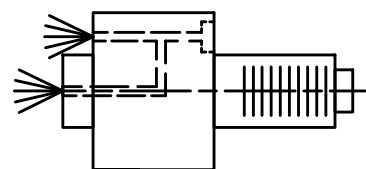

Innen- und Aussenkuehlung / Inside and outside coolant supply  
Kuehlmittelfiltrierung  $< 50\mu$  / coolant filtration  $< 50\mu$

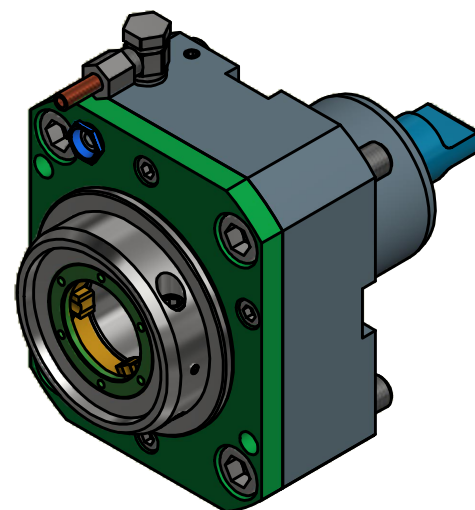

Copyright **EWS Tool Technologies**  
Weitergabe und Vervielfaeltigung dieser Unterlage,  
Verwertung und Mitteilung ihres Inhalts nicht  
gestattet, soweit nicht ausdrecklich zugestanden.  
Zuwiderhandlungen verpflichten zu Schadenersatz.

Bemerkung - Note  
Für Trockenlauf geeignet!  
Use without coolant fluid allowed!

Technische Daten - technical data

Weight	=	6.606 [kg]
Torque max. (M1/M2)	=	100 / 100 [Nm]
Speed max. (n1/n2)	=	10000 / 10000 [1/min]
Gear ratio (i)=n1:n2	=	1:1
Pressure (pmax)	=	70 [bar]

Benennung - Title

**Axial Bohr und Fräskopf**  
**Axial drilling and milling head**



Technische Aenderungen vorbehalten!  
Subject to technical modifications!



Nr. - No.  
**40.60VX4NLIKCHSD10**

IDENT: DEWS136330

REV: -/A

MNR.  
**203899**

