

Bitte überprüfen Sie, ob der Werkzeughalter auf ihrem Revolver im Maschinenraum ohne Kollision durchschwenken kann. Bitte überprüfen Sie auch das Maß 106mm.

Please check the work space of the machine for interferences with the tool holder, especially the swiveling diameter. Please check also the value 106mm.

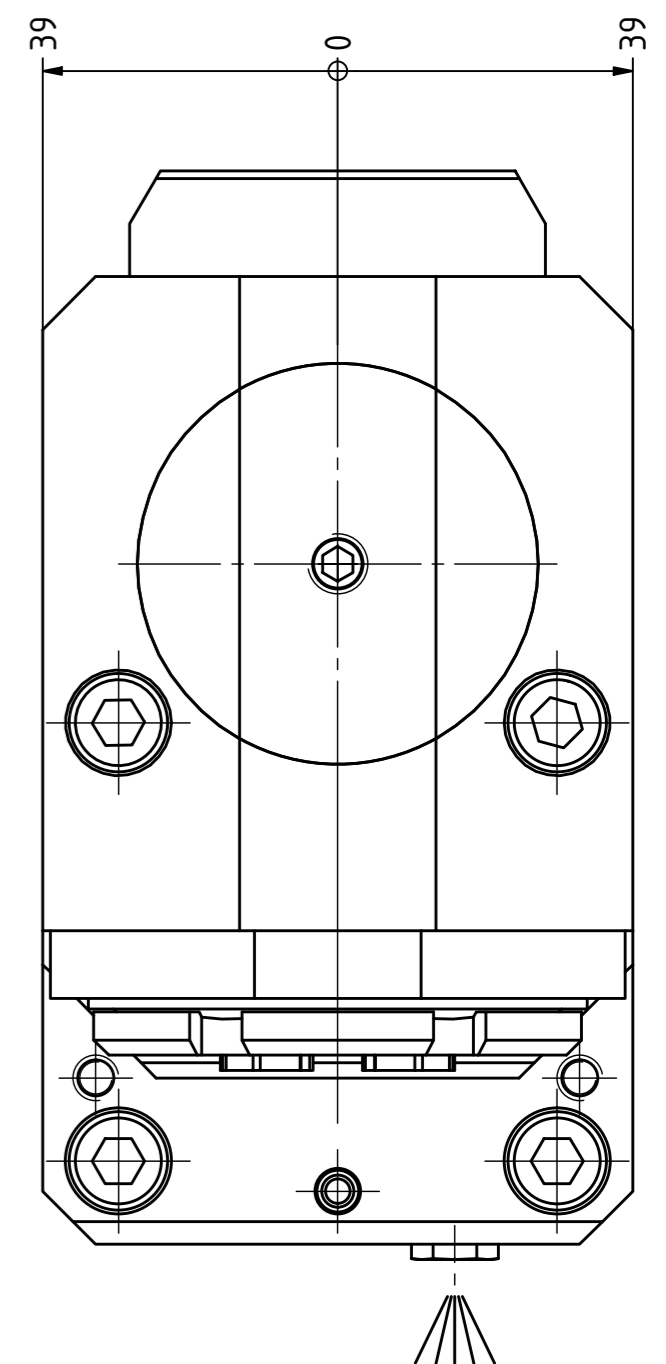

Spannzange / collet ER25 DIN6499
Spannbereich / clamping range: 1,0 - 16,0

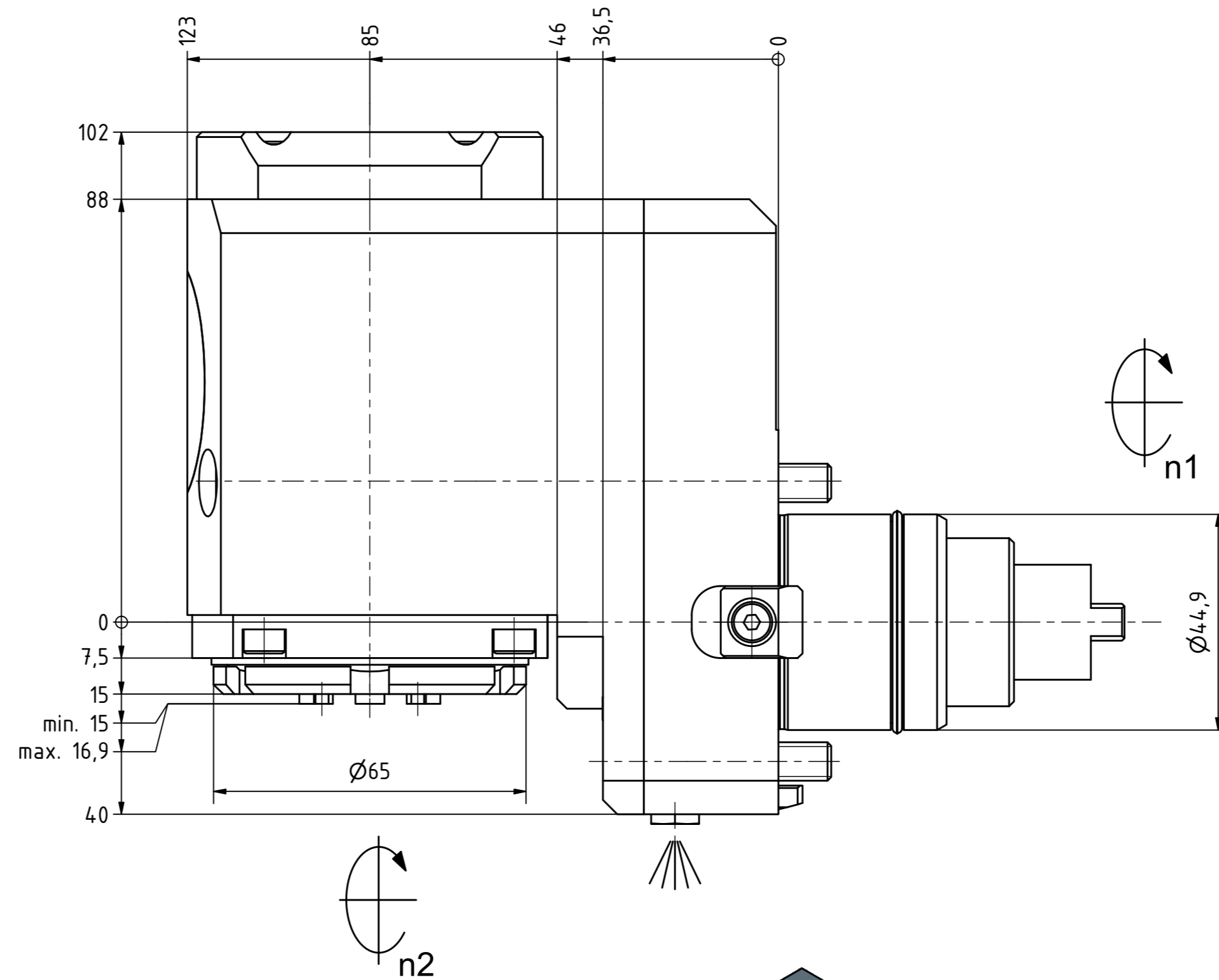
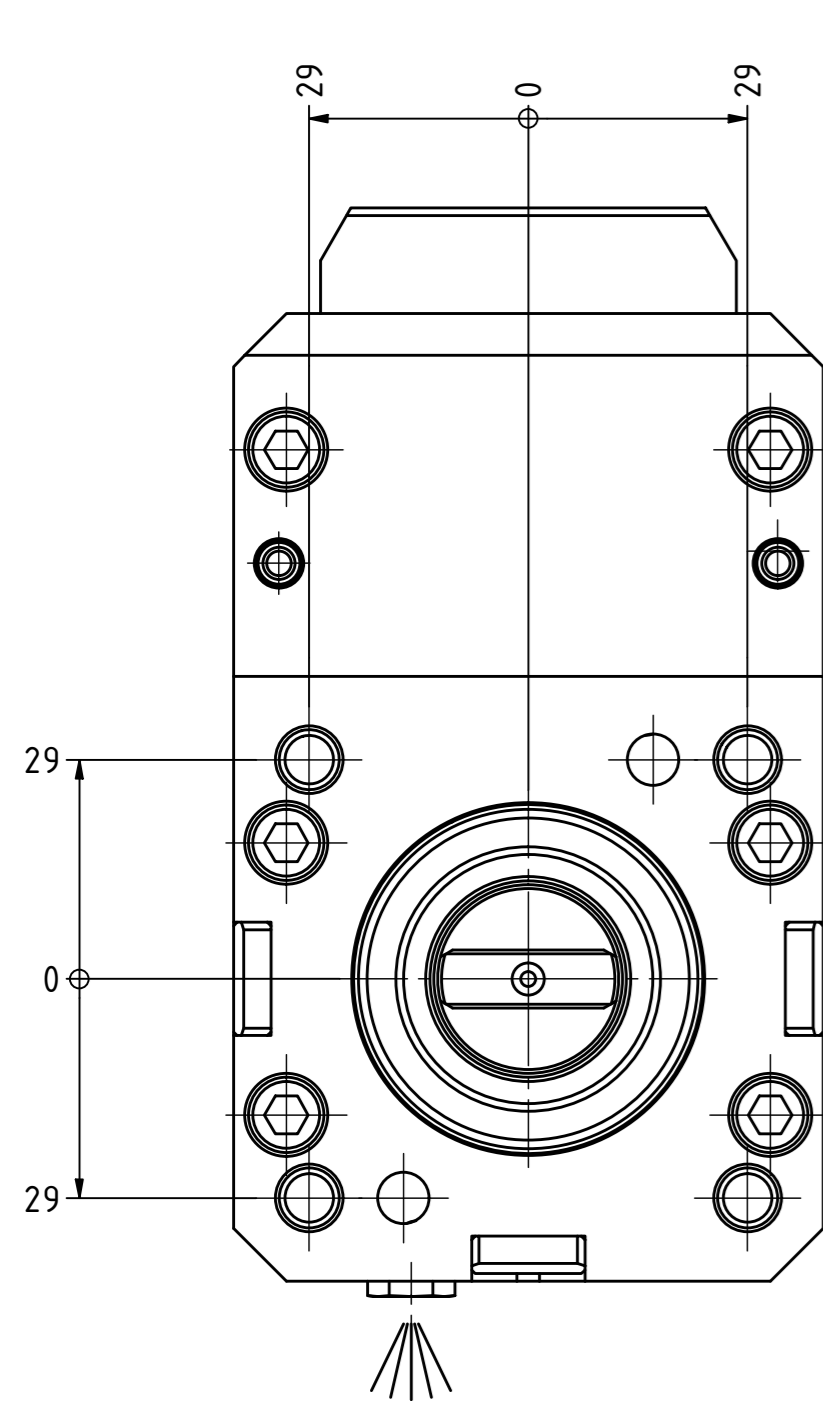

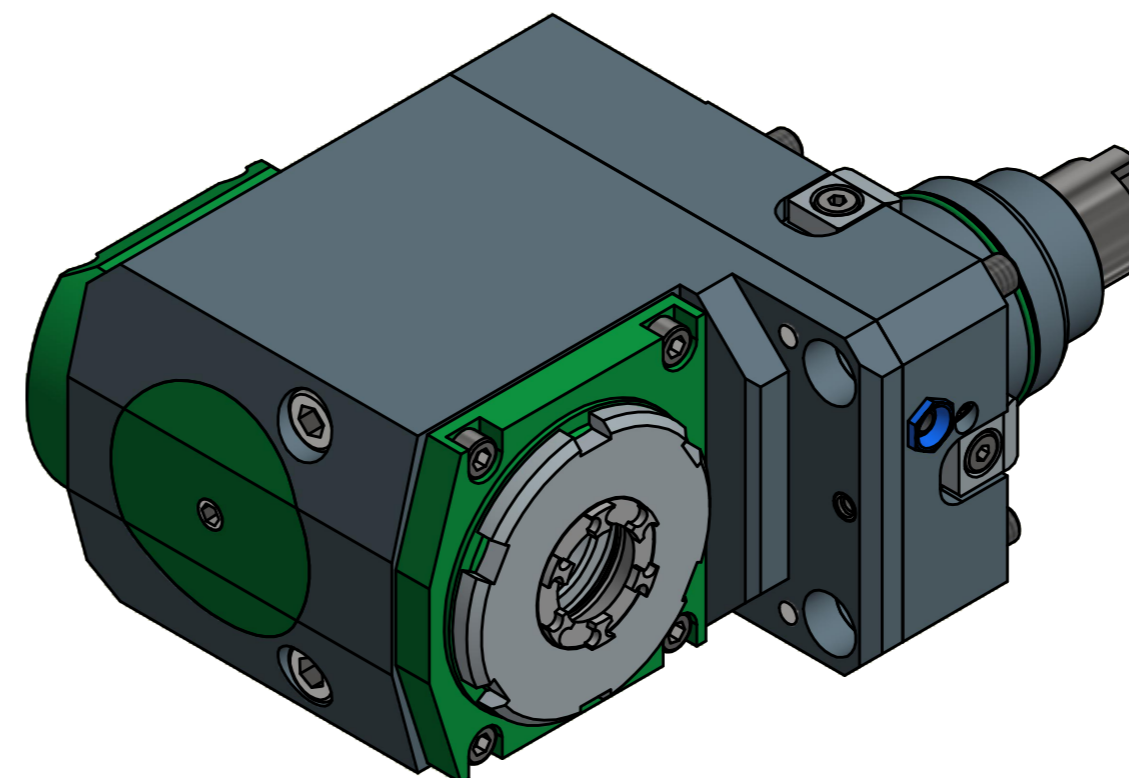
Gewindebohrzange / tapping collet
ET-1-25 M3-M12

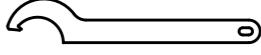

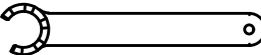
 Hakenschlüssel mit Nase
Hook wrench with nose end
DIN1810 A 68x75

 Spannzangenschlüssel für innenliegende Mutter
Clamping wrench for internal collet
225AX

Copyright **EWS Tool Technologies**
Weitergabe und Vervielfältigung dieser Unterlage, Verwertung und Mitteilung ihres Inhalts nicht gestattet, soweit nicht ausdrücklich zugestanden. Zuwiderhandlungen verpflichten zu Schadenersatz.

Bemerkung - Note 	Technische Daten - technical data Weight = 7.275 [kg] Torque max. (M1/M2) = 50 / 50 [Nm] Speed max. (n1/n2) = 6000 / 6000 [1/min] Gear ratio (i)=n1:n2 = 1:1	Benennung - Title Radial Bohr und Fräskopf, zurückges Radial drill. and mill. head offset	 EWS Weigle GmbH & Co. KG Maybachstr. 1 D-73066 Ulm/ingen www.ews-tools.de	Technische Änderungen vorbehalten! Subject to technical modifications! IDENT: DEWS14.0122 REV: -/A MNR.	
		Nr. - No. 80.4525TC600GLIMX85	204032		