

Capto C4-Aufnahme
Capto C4-Adaptor

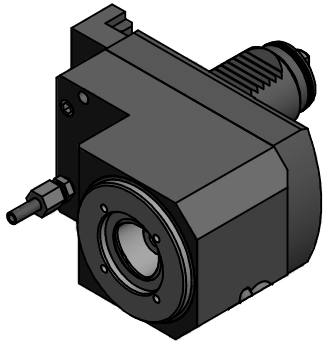

Copyright **EWS Tool Technologies**
Weitergabe und Vervielfältigung dieser Unterlage,
Verwertung und Mitteilung ihres Inhalts nicht
gestattet, soweit nicht ausdrücklich zugestanden.
Zuwerhandlungen verpflichten zu Schadenersatz.

Bemerkung - Note	Technische Daten - technical data Weight = 4.327 [kg] Torque max. (M1/M2) = 50 / 50 [Nm] Speed max. (n1/n2) = 6000 / 6000 [1/min] Gear ratio (i)=n1:n2 = 1:1	Benennung - Title	 <small>EWS Weiglste GmbH & Co. KG Maybachstr. 1 D-73066 Uhingen www.ews-tools.de</small> Nr. - No. 50.40C4MT20R	Technische Änderungen vorbehalten! Subject to technical modifications! IDENT: DEWS04.0202	 REV: -/A MNR. 203800	
------------------	--	-------------------	---	---	--	---