

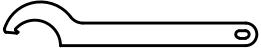

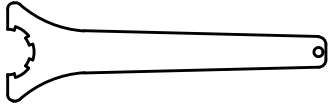

-  Hakenschlüssel mit Nase
-  Spannzangenschlüssel
- DIN1810 A 58x62 232

Spannzange / collet ER32 DIN6499  
Spannbereich / clamping range: 2,0 - 20,0

Gewindebohrzange / tapping collet  
ET-1-32 M5-M12

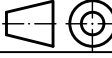
Copyright **EWS Tool Technologies**  
Weitergabe und Vervielfaeltigung dieser Unterlage,  
Verwertung und Mitteilung ihres Inhalts nicht  
gestattet, soweit nicht ausdrecklich zugestanden.  
Zuwiderhandlungen verpflichten zu Schadenersatz.

Bemerkung - Note	Technische Daten - technical data <b>Weight</b> = 7.293 [kg] <b>Torque max. (M1/M2)</b> = 50 / 25 [Nm] <b>Speed max. (n1/n2)</b> = 6000 / 12000 [1/min] <b>Gear ratio (i)=n1:n2</b> = 1:2	Benennung - Title <b>Radial Bohr und Fräskopf, zurückges</b> <b>Radial drill. and mill. head offset</b>	 <b>EWS</b> <small>EWS Weigele GmbH &amp; Co. KG          Maybachstr. 1          D-73066 Uhingen          www.ews-tools.de</small>	Technische Aenderungen vorbehalten! Subject to technical modifications! IDENT: D-EWS-161928	 REV: -/- MNR. 176703	
			Nr. - No. <b>80.4032CTXR11AP42.5</b>			