



EWS.Varia



Ceramic Seal



Tech Details

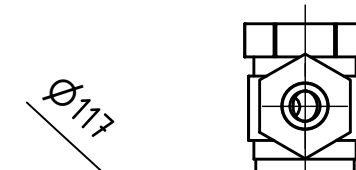
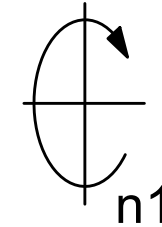
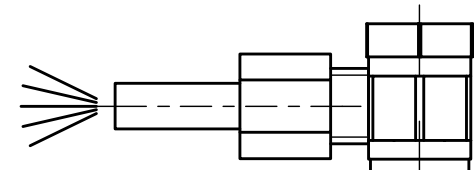
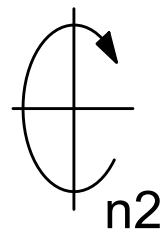

Ø117

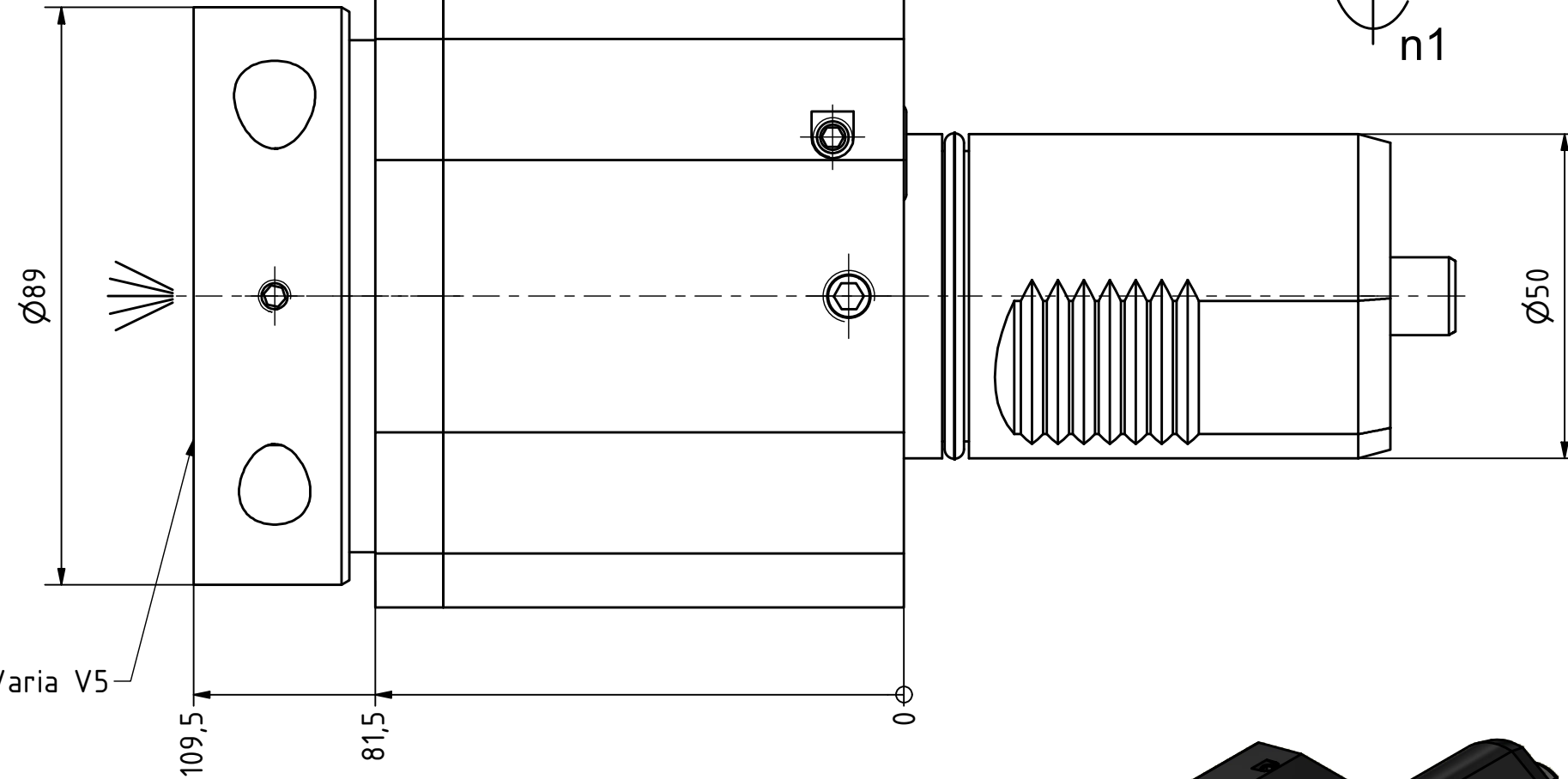
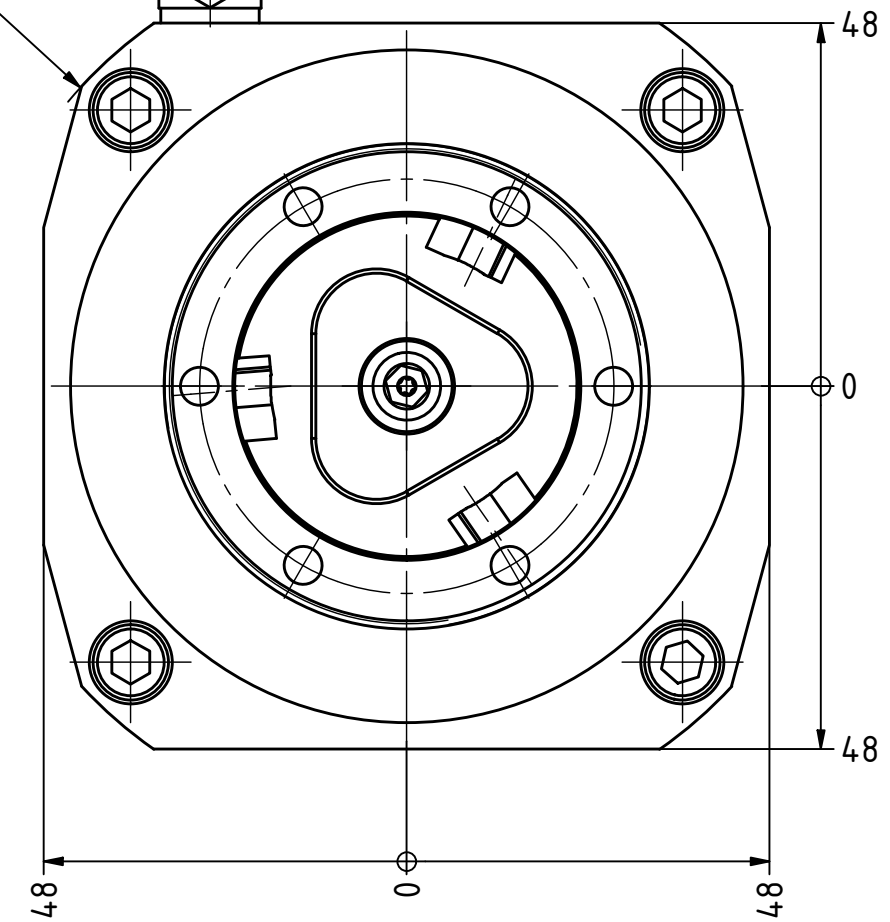

EWS-Varia V5

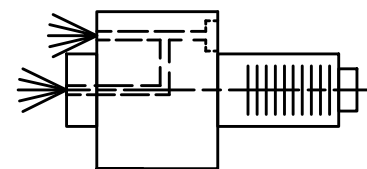

Innen- und Aussenkuehlung / Inside and outside coolant supply  
Kuehlmittelfiltrierung<50µ / coolant filtration<50µ

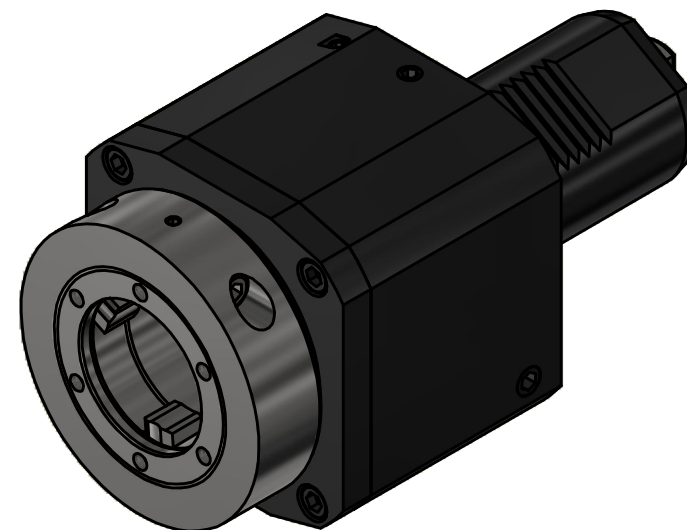

Copyright **EWS Tool Technologies**  
Weitergabe und Vervielfaeltigung dieser Unterlage,  
Verwertung und Mitteilung ihres Inhalts nicht  
gestattet, soweit nicht ausdrucklich zugestanden.  
Zuwiderhandlungen verpflichten zu Schadenersatz.

Bemerkung - Note

Für Trockenlauf geeignet!  
Use without coolant fluid allowed!

Technische Daten - technical data

Weight = 6.370 [kg]  
Torque max. (M1/M2) = 100 / 100 [Nm]  
Speed max. (n1/n2) = 4000 / 4000 [1/min]  
Gear ratio (i)=n1:n2 = 1:1  
Pressure (pmax) = 70 [bar]

Benennung - Title

**Axial Bohr und Fräskopf**  
**Axial drilling and milling head**



Nr. - No.

**40.50V5SQT28IKC**

EWS Weigele GmbH & Co. KG  
Maybachstr. 1  
D-73066 UHINGEN  
www.ews-tools.de

Technische Aenderungen vorbehalten!  
Subject to technical modifications!

IDENT: DEWS234736

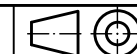

REV: -/A

MNR.

**163860**

