

W-Verzahnung Lizenz Index-Werke
W-tooth system licence Index-Corporation

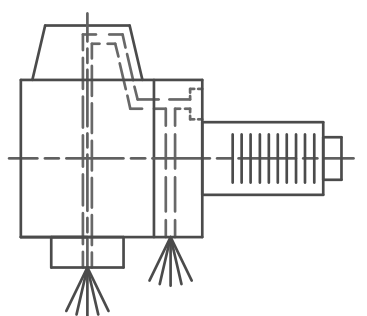

Innen- und Aussenkuehlung / *Inside and outside coolant supply*
 Kein Trockenlauf / *No dry run*
 Kuehmittelfiltrierung <math>< 50\mu</math> / *coolant filtration <math>< 50\mu</math>*

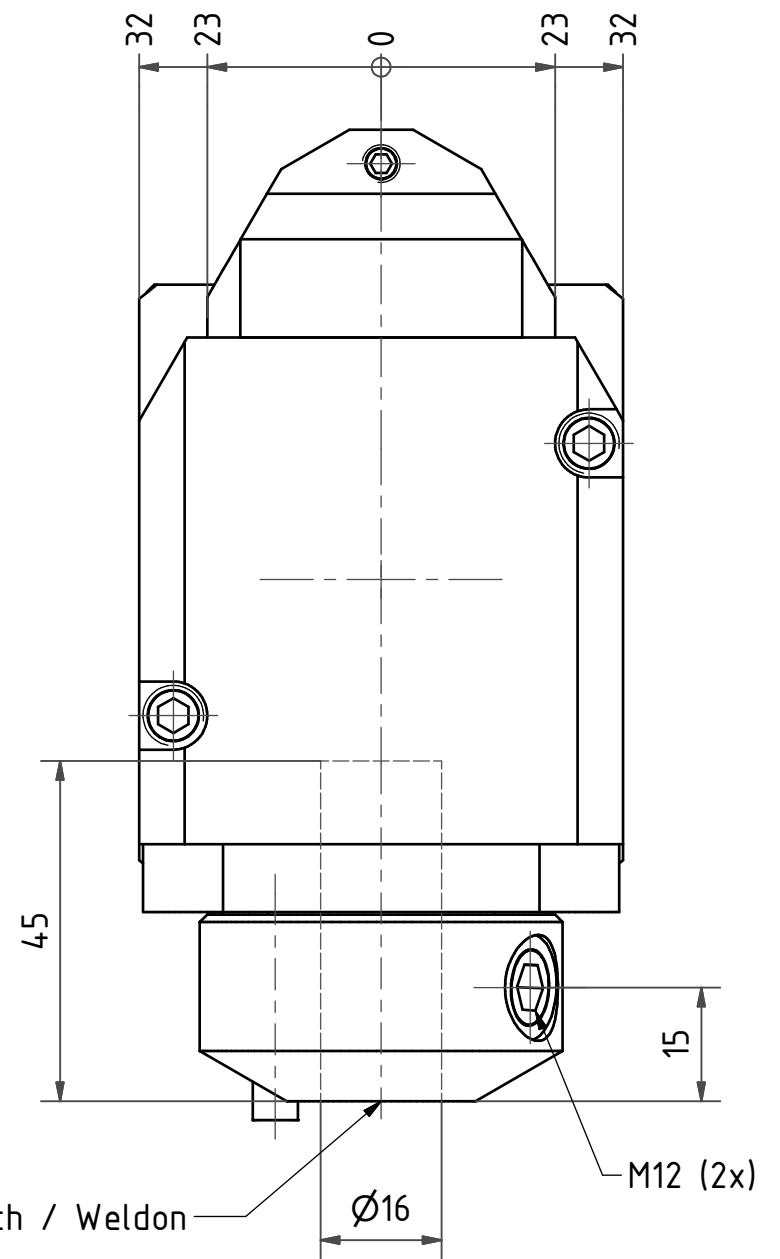
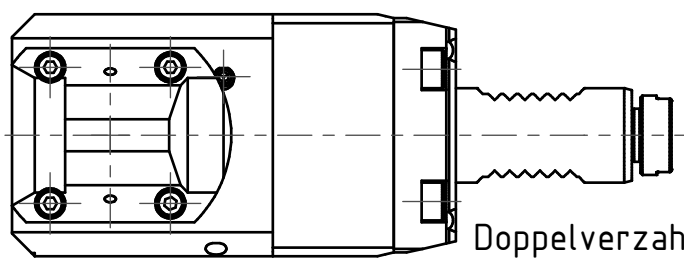

Doppelverzahnung Lizenz Traub
double tooth system licence Traub

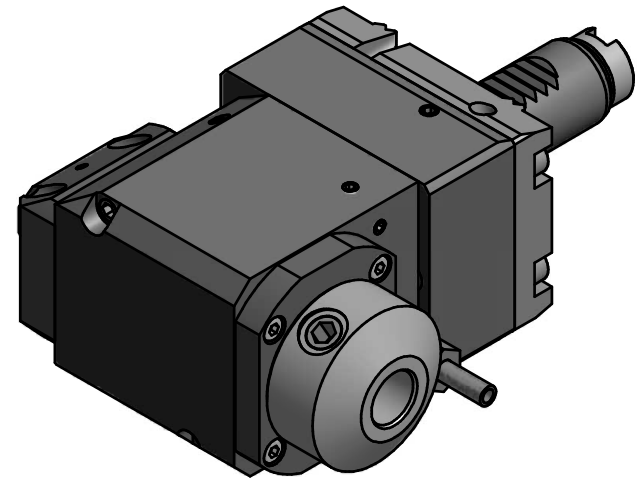

Copyright **EWS Tool Technologies**
 Weitergabe und Vervielfaeltigung dieser Unterlage,
 Verwertung und Mitteilung ihres Inhalts nicht
 gestattet, soweit nicht ausdrecklich zugestanden.
 Zuwiderhandlungen verpflichten zu Schadenersatz.

Bemerkung - *Note*
 Nicht ohne Kuehlmittel betreiben!
Not for use without coolant-fluid!

Technische Daten - <i>technical data</i>	
Weight	= 4.438 [kg]
Torque max. (M1/M2)	= 25 / 25 [Nm]
Speed max. (n1/n2)	= 8000 / 8000 [1/min]
Gear ratio (i)=n1:n2	= 1:1
Pressure (pmax)	= 70 [bar]

Benennung - *Title*
Radial Bohr und Fräskopf
Radial drilling and milling head

EWS Tool Technologies
 EWS Weigele GmbH & Co. KG
 Maybachstr. 1
 D-73066 Uhingen
 www.ews-tools.de

Technische Aenderungen vorbehalten! <i>Subject to technical modifications!</i>	
IDENT: D-EWS-161848	REV: -/-
Nr. - No.	MNR.
60.2516WNG200RLIKWX90	176647

