

max. 120
min. 116,5

Spannzange / collet ER25 DIN6499
Spannbereich / clamping range: 1,0 - 16,0

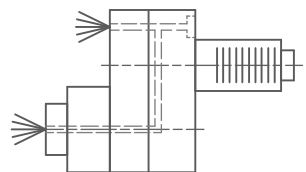

Innen- und Aussenkuehlung / Inside and outside coolant supply
Kein Trockenlauf / No dry run
Kuehlmittelfiltrierung-50µ / coolant filtration-50µ

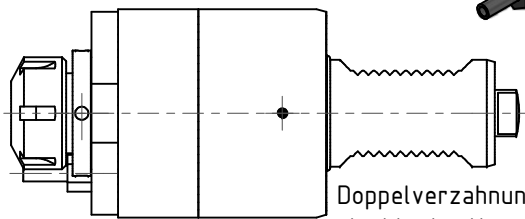

Doppelverzahnung Lizenz Traub
double tooth system licence Traub

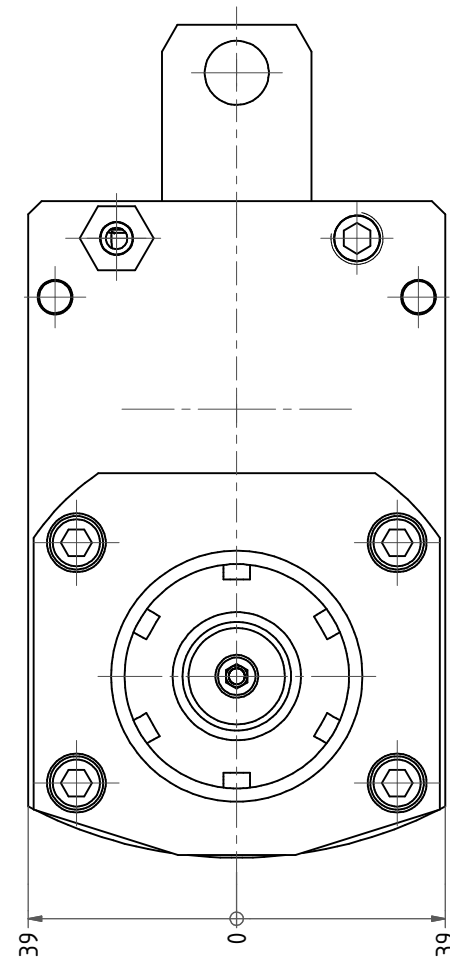
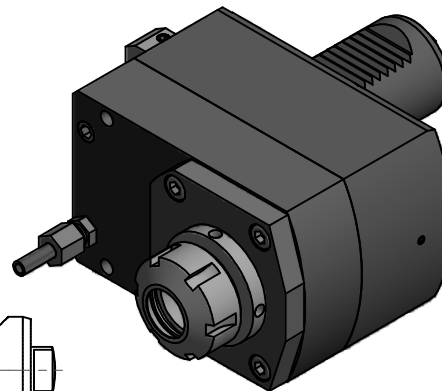

Hakenschlüssel
mit Zapfen
Hook wrench
with fixed pin
DIN1810 B 45x50

Spannzangenschlüssel
Clamping wrench
225

Copyright **EWS Tool Technologies**
Weitergabe und Vervielfaeltigung dieser Unterlage,
Verwertung und Mitteilung ihres Inhalts nicht
gestattet, soweit nicht ausdruercklich zugestanden.
Zuwiderhandlungen verpflichten zu Schadenersatz.

Bemerkung - Note	Technische Daten - technical data	
	<p>Weight = 6.235 [kg] Torque max. (M1/M2) = 50 / 25 [Nm] Speed max. (n1/n2) = 6000 / 12000 [1/min] Gear ratio (i)=n1:n2 = 1:2 Pressure (pmax) = 70 [bar]</p>	

Benennung - Title	
-------------------	--

 <small>EWS Weigelt GmbH & Co. KG Maybachstr. 1 D-73066 Uhingen www.ews-tools.de</small>	Technische Aenderungen vorbehalten! Subject to technical modifications! IDENT: DEWS021915
	Nr. - No. 50.40251809RLIK11

MNR. 203424

