

Spannzange / collet ER40 DIN6499
 Spannungsbereich / clamping range: 3,0 - 26,0

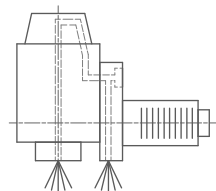

Innen- und Aussenkuehlung / Inside and outside coolant supply
 Kein Trockenlauf / No dry run
 Kuehlmittelfiltrierung50μ / coolant filtration50μ

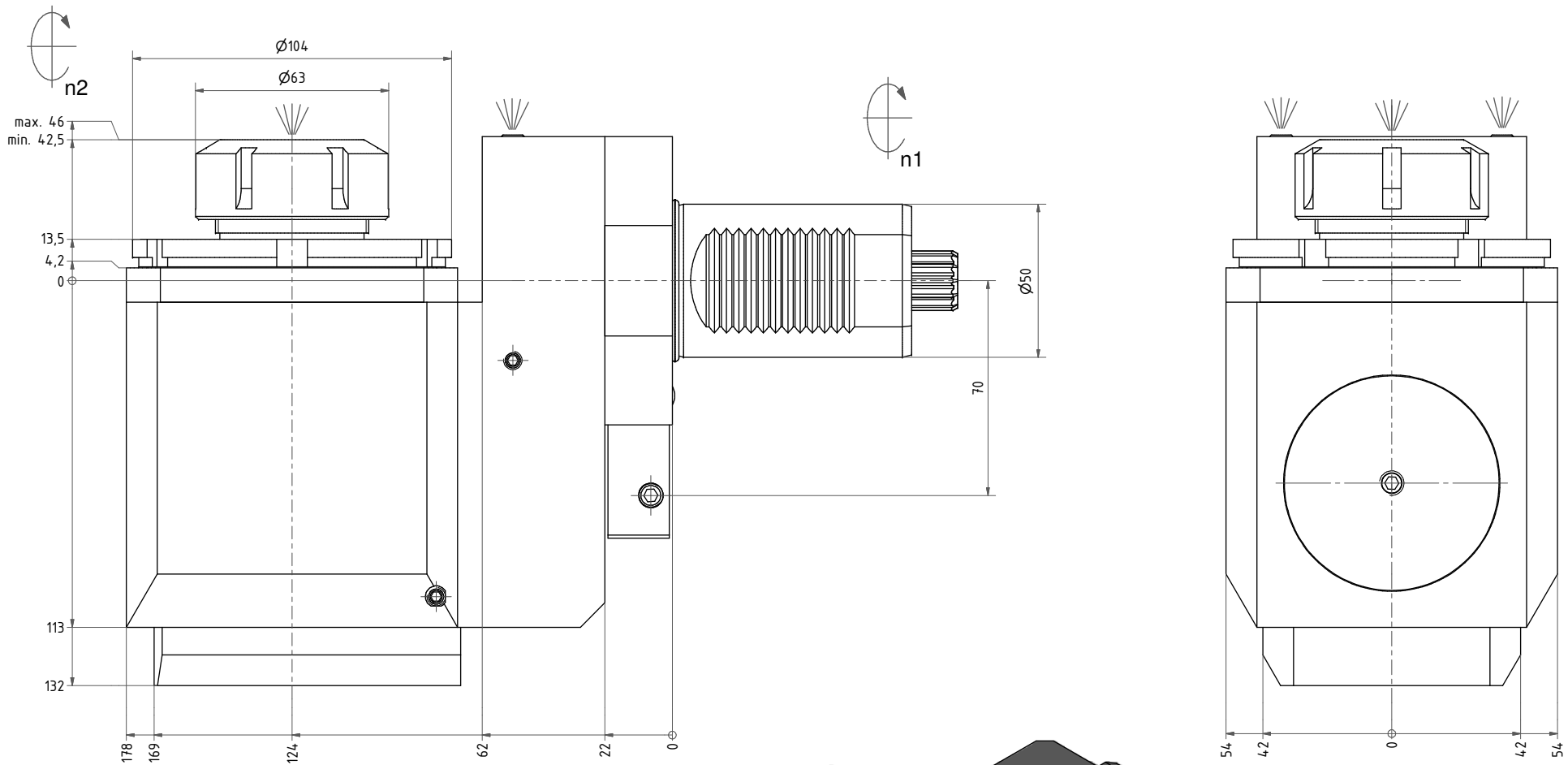
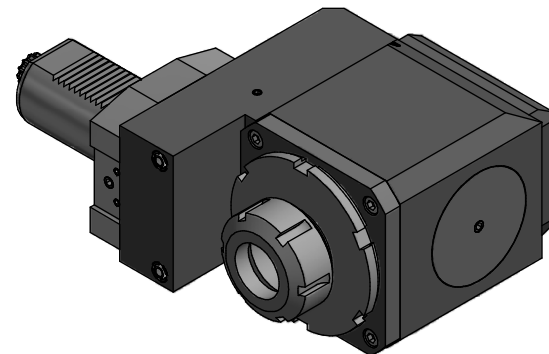

Hakenschlüssel
 mit Nase
 Hook wrench with
 nose end
 DIN1810 A 95x100

Spannzangenschlüssel
 Clamping wrench
 240

Copyright EWS Tool Technologies
 Weitergabe und Vervielfaeltigung dieser Unterlage,
 Verwertung und Mitteilung ihres Inhalts nicht
 gestattet, soweit nicht ausdrecklich zugestanden.
 Zuwiderhandlungen verpflichten zu Schadenersatz.

Bemerkung - Note	Technische Daten - Technical data	Bemerkung - Note
Nicht ohne Kuehlmittel betreiben! Not for use without coolant-fluid! mit Kegelrollenlager with taper roller bearing(s)	Weight = 16.734 [kg] Torque max. (M1/M2) = 80 / 160 [Nm] Speed max. (n1/n2) = 4.000 / 2000 [1/min] Gear ratio (i)=n1:n2 = 2:1 Pressure (pmax) = 70 [bar]	

EWS Tool Technologies <small>EWS Werkzeug GmbH & Co. KG D-72084 Löhningen www.ews-tool.de</small>	Technische Änderungen vorbehalten! Subject to technical modifications! IDENT: DEWS018186	REV: -/A 7/18	
	Nr. - No. 80.504.0KR54.82LIK12	202657	