

Spannzange / collet ER40 DIN6499  
 Spannbereich / clamping range: 3,0 - 26,0

Gewindebohrzange / tapping collet  
 ET-1-40 M6-M16

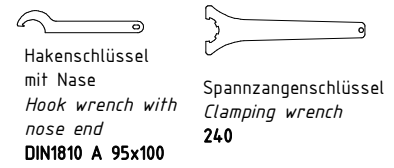
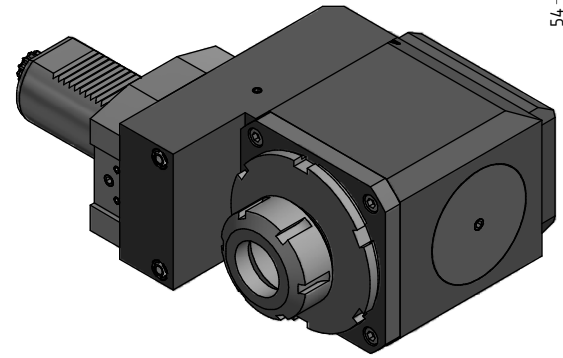
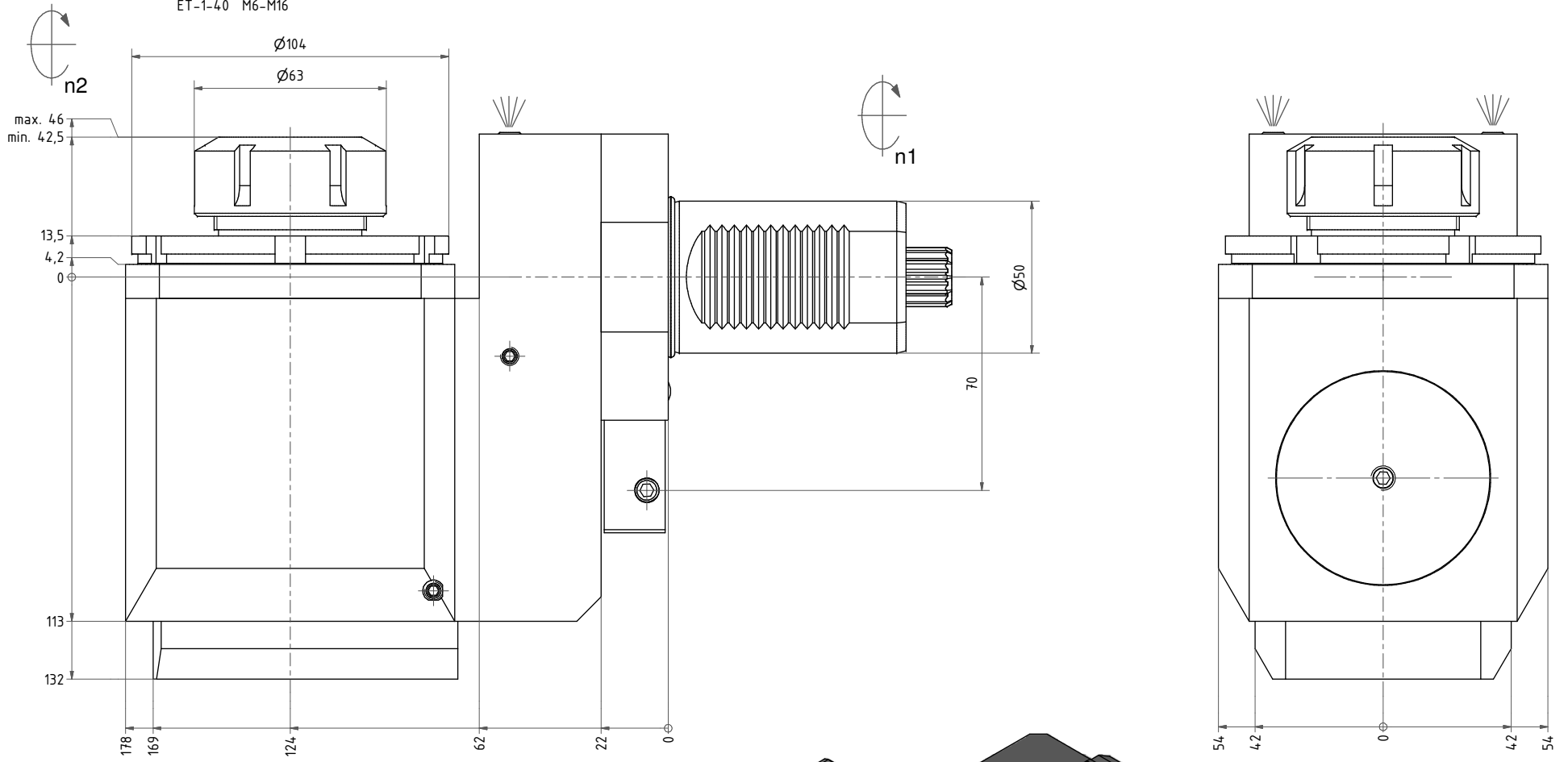

Copyright EWS Tool Technologies  
 Weitergabe und Vervielfältigung dieser Unterlage,  
 Verwertung und Mitteilung ihres Inhalts nicht  
 gestattet, soweit nicht ausdrücklich zugestanden.  
 Zuwiderhandlungen verpflichten zu Schadenersatz.

Bemerkung - Note  mit Kegelrollenlager with taper roller bearing(s)	Technische Daten - Technical data Weight = 16.718 [kg] Torque max. (M1/M2) = 80 / 160 [Nm] Speed max. (n1/n2) = 4.000 / 2000 [1/min] Gear ratio (i)=n1:n2 = 2:1	Bemerkung - Title  EWS Tool Technologies EWS Werkzeug GmbH & Co. KG Hauptstr. 1 D-72084 Löhningen www.ews-tool.de	Technische Änderungen vorbehalten! Subject to technical modifications! IDENT: DEWS018197 REV: -/A 7/18	QR
--	---	--	--	----

80.504.0KR54.82LI2

202655