

Spannzange / collet ER32 DIN6499
 Spannungsbereich / clamping range: 2,0 - 20,0

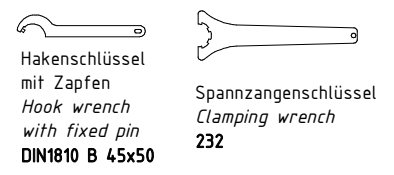
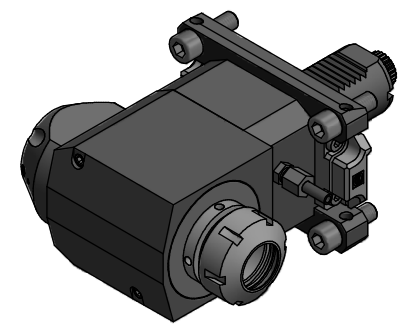

Innen- und Aussenkuehlung / Inside and outside coolant supply
 Kein Trockenlauf / No dry run
 Kuehlmittefiltrierung-50µ / coolant filtration-50µ

Bemerkung - Note Nicht ohne Kuehlmittel betreiben! Not for use without coolant-fluid!	Technische Daten - Technical data	Bemerkung - Note	
	Weight		= 7,536 [kg]
	Torque max. (M1/M2)		= 50 / 50 [Nm]
	Speed max. (n1/n2)		= 10000 / 10000 [1/min]
	Gear ratio (i)=n1:n2		= 1:1
Pressure (pmax)	= 70 [bar]		

 <small>EWS Werkzeug GmbH & Co. KG D-72084 Löhningen www.ews-tool.de</small>	<small>Technische Änderungen vorbehalten! Subject to technical modifications!</small>	
	<small>IDENT: DEWS016014</small>	<small>REV: -/A</small>
<small>Nr. - No.</small> 60.4032CTXRIKTf-PLHSD10	<small>7/18</small> 202209	

Copyright EWS Tool Technologies
 Weitergabe und Vervielfaeltigung dieser Unterlage,
 Verwertung und Mitteilung ihres Inhalts nicht
 gestattet, soweit nicht ausdrecklich zugestanden.
 Zuwiderhandlungen verpflichten zu Schadenersatz.