

Spannzange / Collet ER11 DIN6499  
 Spannungsbereich / Clamping range: 0,5 - 7,0

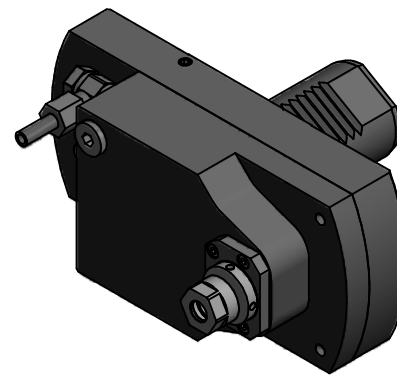

Hakenschlüssel  
 mit Zapfen  
 Hook wrench  
 with fixed pin  
 DIN1810 B 25x28

Copyright **EWS Tool Technologies**  
 Weitergabe und Vervielfältigung dieser Unterlage,  
 Verwertung und Mitteilung ihres Inhalts nicht  
 gestattet, soweit nicht ausdrücklich zugestanden.  
 Zuwiderhandlungen verpflichten zu Schadenersatz.

Bemerkung - Note	Technische Daten - technical data Weight = 4,154 [kg] Torque max. (M1/M2) = 10 / 10 [Nm] Speed max. (n1/n2) = 6000 / 6000 [1/min] Gear ratio (i)=n1:n2 = 1:1	Benennung - Title	 EWS Weigelt GmbH & Co. KG Maybachstr. 1 D-73066 Uhingen www.ews-tools.de	Technische Änderungen vorbehalten! Subject to technical modifications! IDENT: DEWS012371	 REV: -/A MNR.	
			Nr. - No. <b>50.4012SQT10R-S01</b>	<b>201586</b>		