

Spannzange / collet ER25 DIN6499
 Spannbereich / clamping range: 1,0 - 16,0

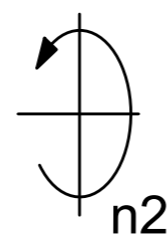

Z (2 : 1)

Ausrichtklotz ist über einen Exzenter einstellbar.
 The block is adjustable via eccentric.

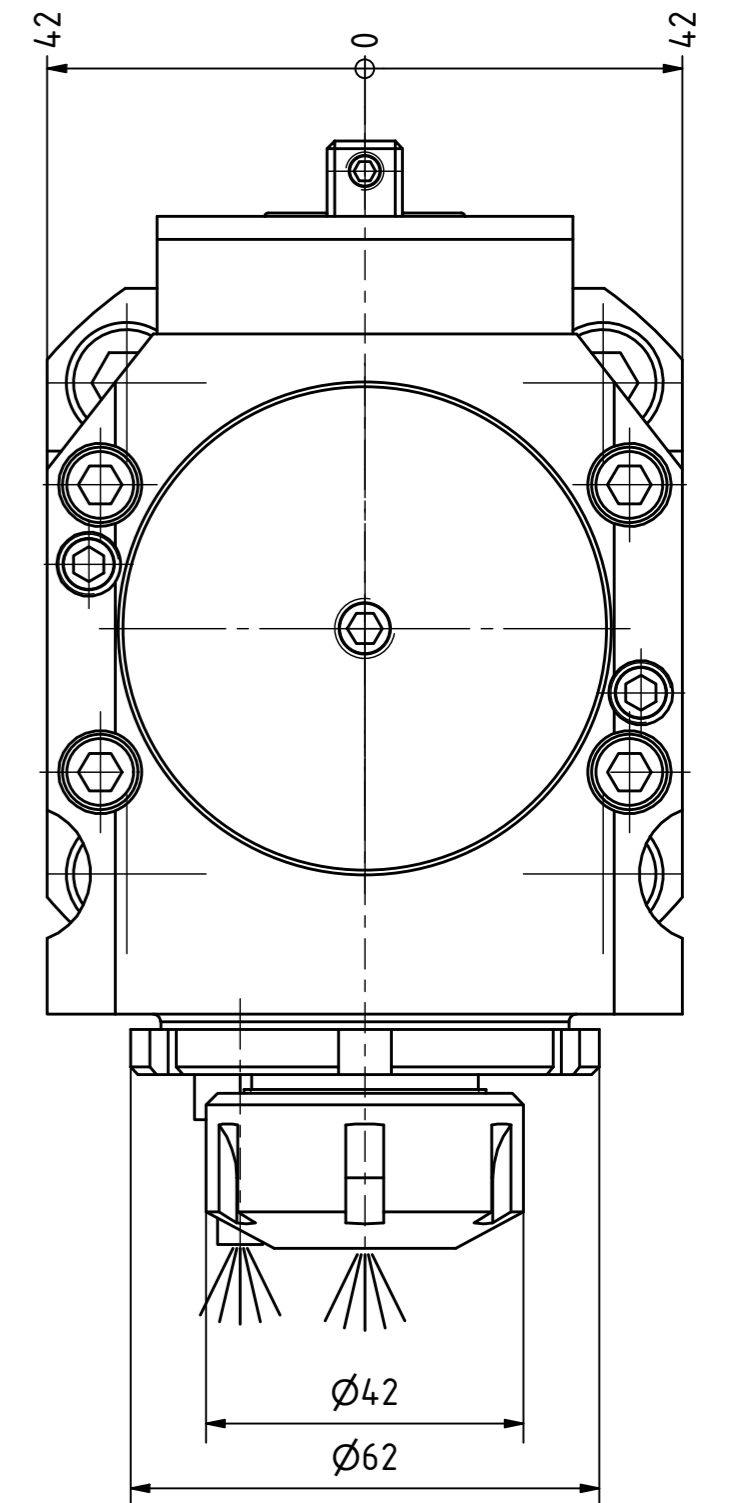
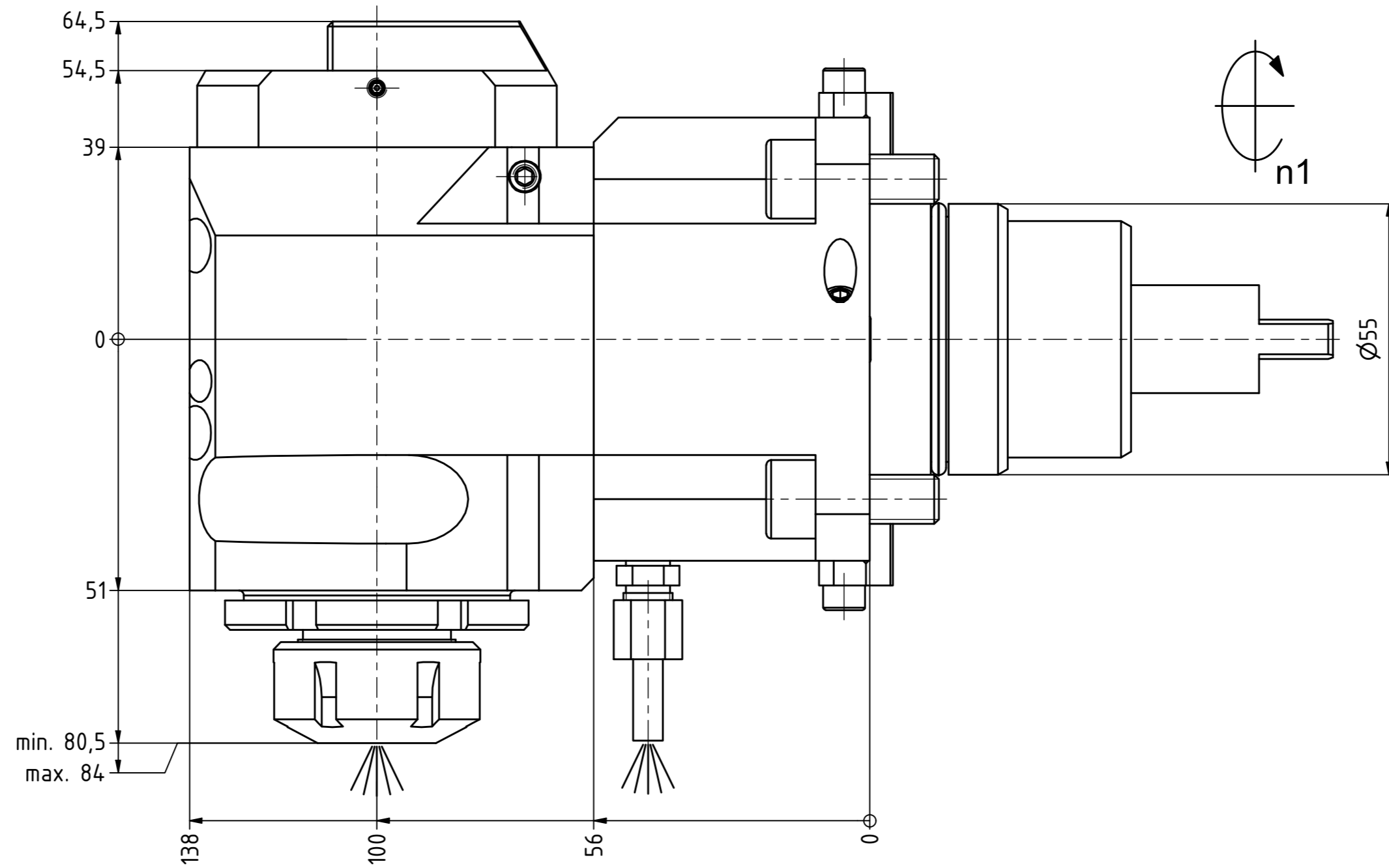
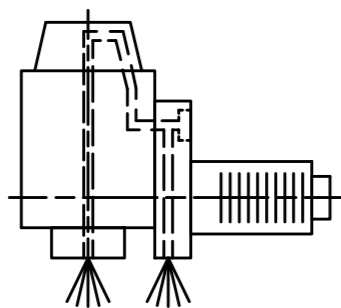
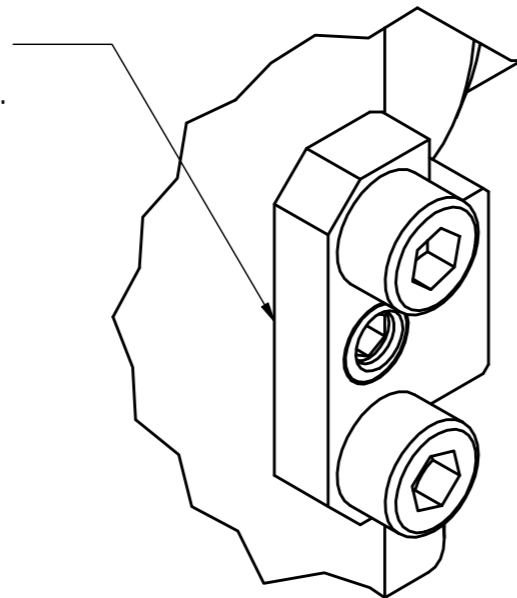

Innen- und Aussenkuehlung / Inside and outside coolant supply
 Kein Trockenlauf / No dry run
 Kuehlmittelfiltrierung-50µ / coolant filtration-50µ

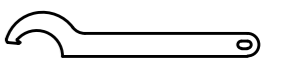
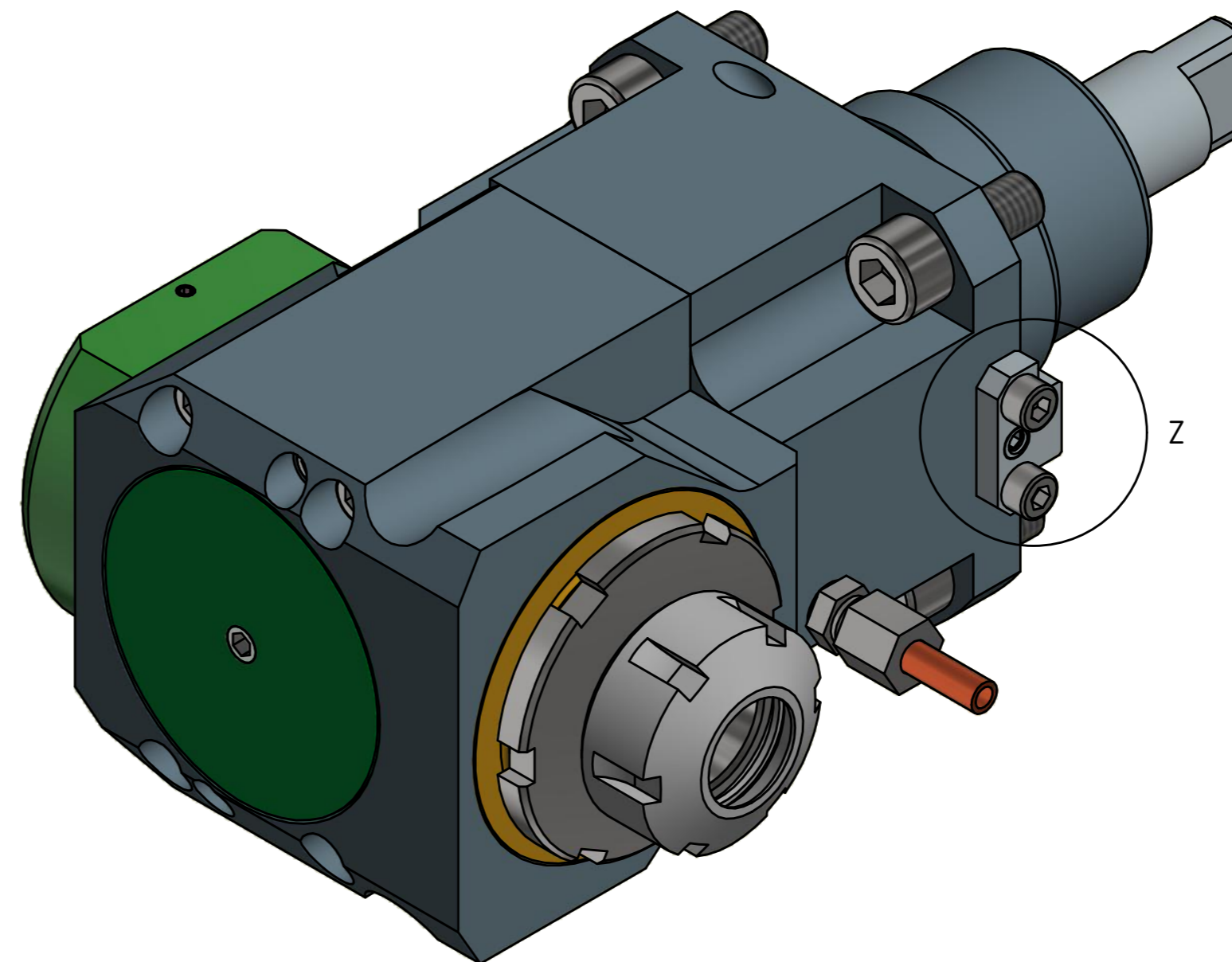

Hakenschlüssel mit Nase
 Hook wrench with nose end
 DIN1810 A 58x62

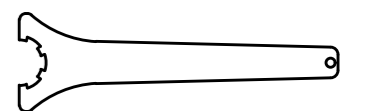

Spannzangenschlüssel
 Clamping wrench
 225

Copyright **EWS Tool Technologies**
 Weitergabe und Vervielfaeltigung dieser Unterlage, Verwertung und Mitteilung ihres Inhalts nicht gestattet, soweit nicht ausdruecklich zugestanden. Zuwiderhandlungen verpflichten zu Schadenersatz.

Bemerkung - Note
 Nicht ohne Kuehlmittel betreiben!
 Not for use without coolant-fluid!

Technische Daten - technical data
 Weight = 7.370 [kg]
 Torque max. (M1/M2) = 50 / 25 [Nm]
 Speed max. (n1/n2) = 6000 / 12000 [1/min]
 Gear ratio (i)=n1:n2 = 1:2
 Pressure (pmax) = 70 [bar]

Benennung - Title
 Radial Bohr und Fräskopf
 Radial drilling and milling head



60.5525BIG1809IK1X100#01

Technische Aenderungen vorbehalten!
 Subject to technical modifications!
 IDENT: DEWS051497

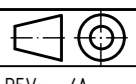

REV: -/A
 MNR.
 209123

QR