

Spannzange / collet ER40 DIN6499  
 Spannbereich / clamping range: 3,0 - 26,0

Gewindebohrzange / tapping collet  
 ET-1-40 M6-M16

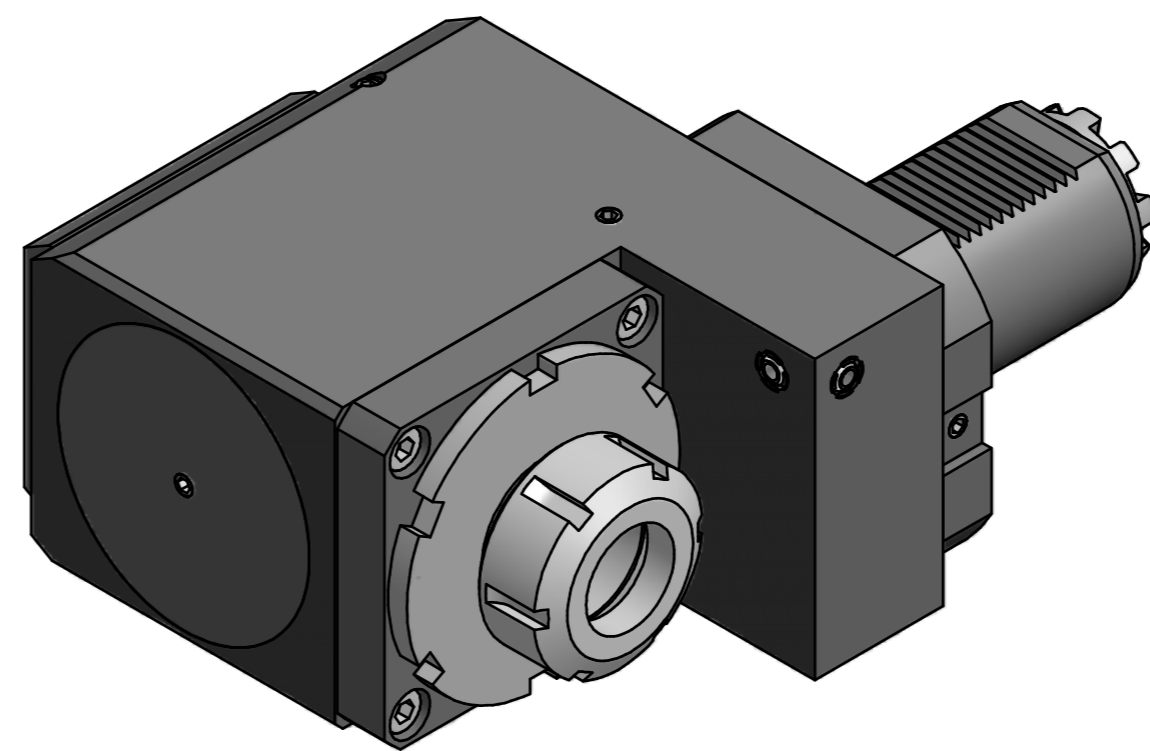
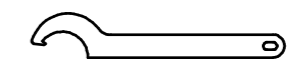
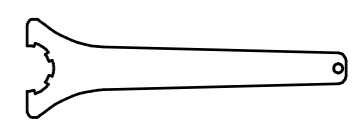

  
 Hakenschlüssel  
 mit Nase  
 Hook wrench with  
 nose end  
 DIN1810 A 95x100

  
 Spannzangenschlüssel  
 Clamping wrench  
 240

Copyright **EWS Tool Technologies**  
 Weitergabe und Vervielfältigung dieser Unterlage,  
 Verwertung und Mitteilung ihres Inhalts nicht  
 gestattet, soweit nicht ausdrücklich zugestanden.  
 Zuwiderhandlungen verpflichten zu Schadenersatz.

Bemerkung - Note mit Kegelrollenlager with taper roller bearing(s)	Technische Daten - Technical data M <sub>1</sub> / M <sub>2</sub> = 160 / 160 Nm n <sub>1</sub> / n <sub>2</sub> = 3000 / 3000 1/min i (N <sub>1</sub> :N <sub>2</sub> ) = 1:1	Benennung - Title <b>Radial Bohr und Fräskopf. zurückges</b> <b>Radial drill. and mill. head offset</b>	<table border="1"> <tr> <th>name</th> <th>date</th> </tr> <tr> <td>M. Simoniello</td> <td>17.01.2013</td> </tr> </table>	name	date	M. Simoniello	17.01.2013	Technische Änderungen vorbehalten! Subject to technical modifications! Nr. <b>80.6040KRHEYR</b> MNR: 162605 IDENT: D-EWS-130885 - Blatt - page 1 (1)
name	date							
M. Simoniello	17.01.2013							

