

Z (2:1)

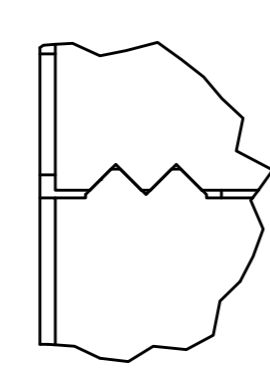

Gewindebohrungen für Winkelausrichtung
Thread holes for angle adjusting.

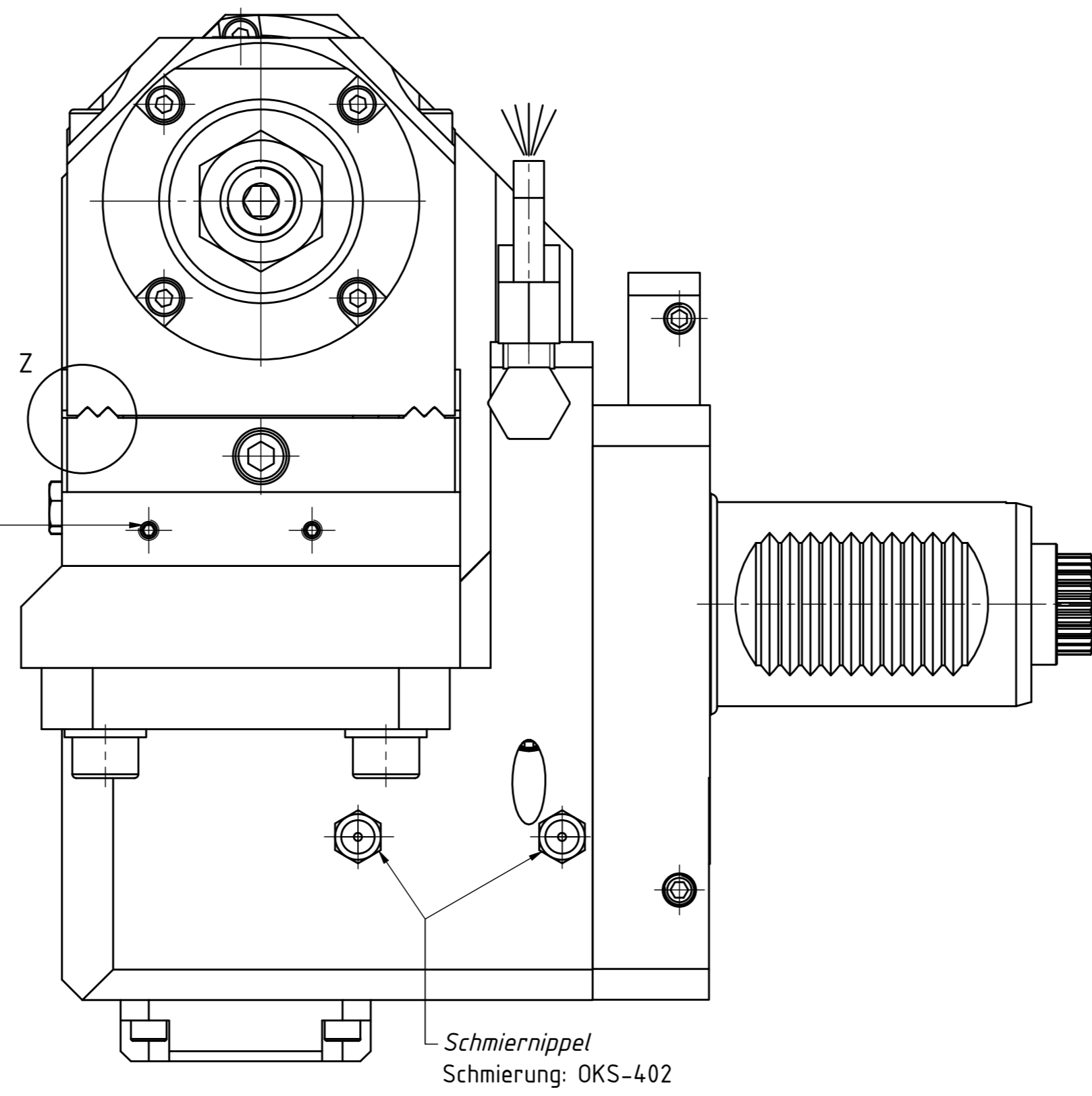

Schmiernippel
Schmierung: OKS-402

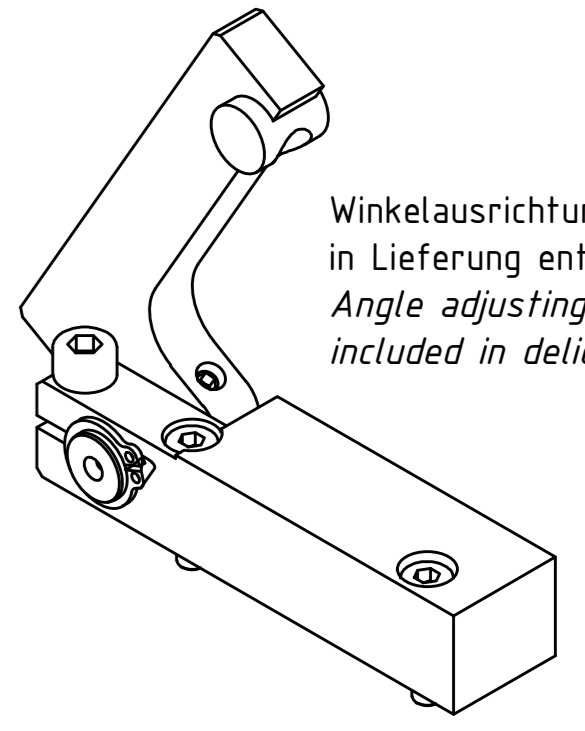

Winkelausrichtung & CD-ROM
in Lieferung enthalten!
Angle adjusting & CD-ROM
included in delivery!

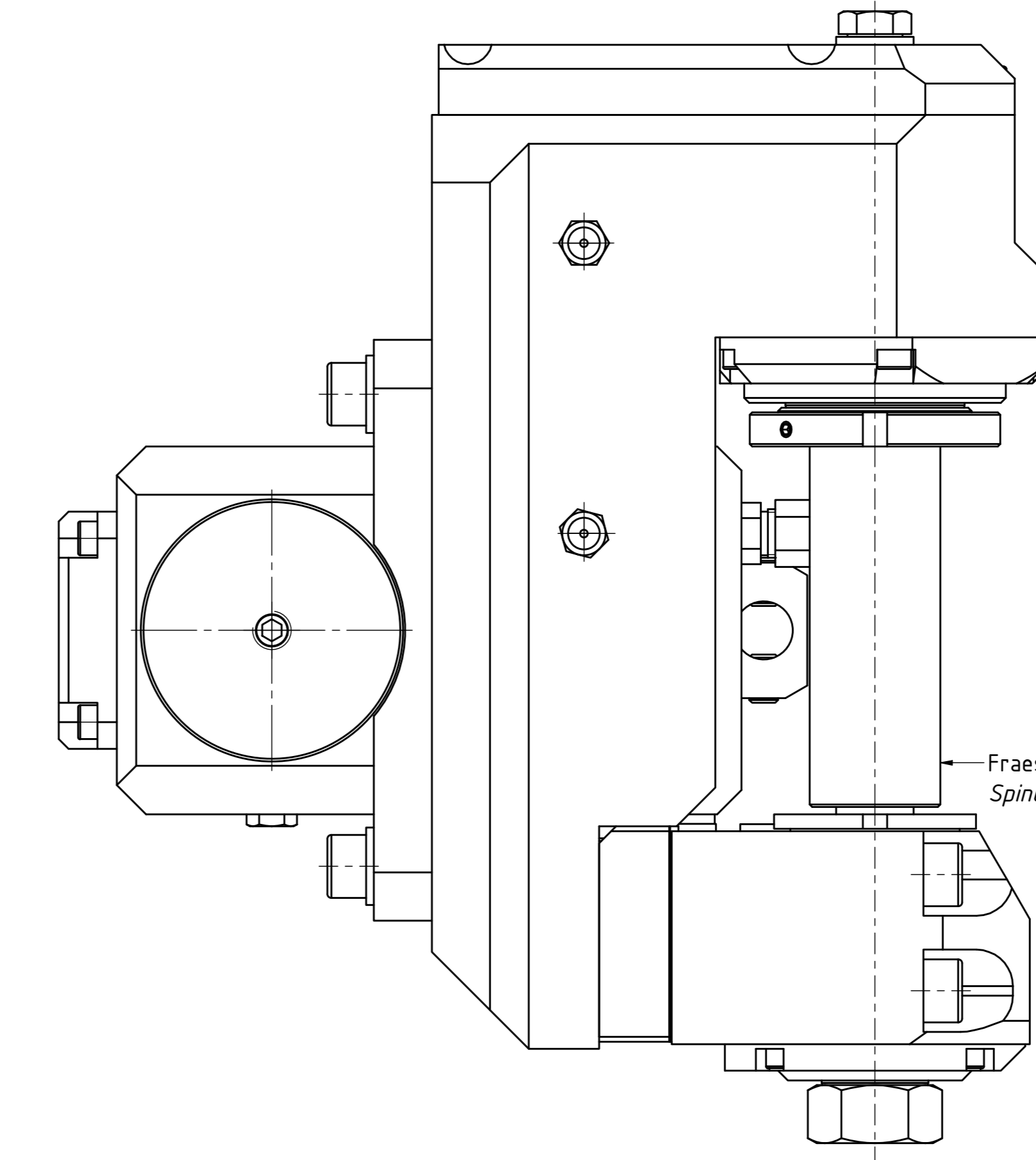
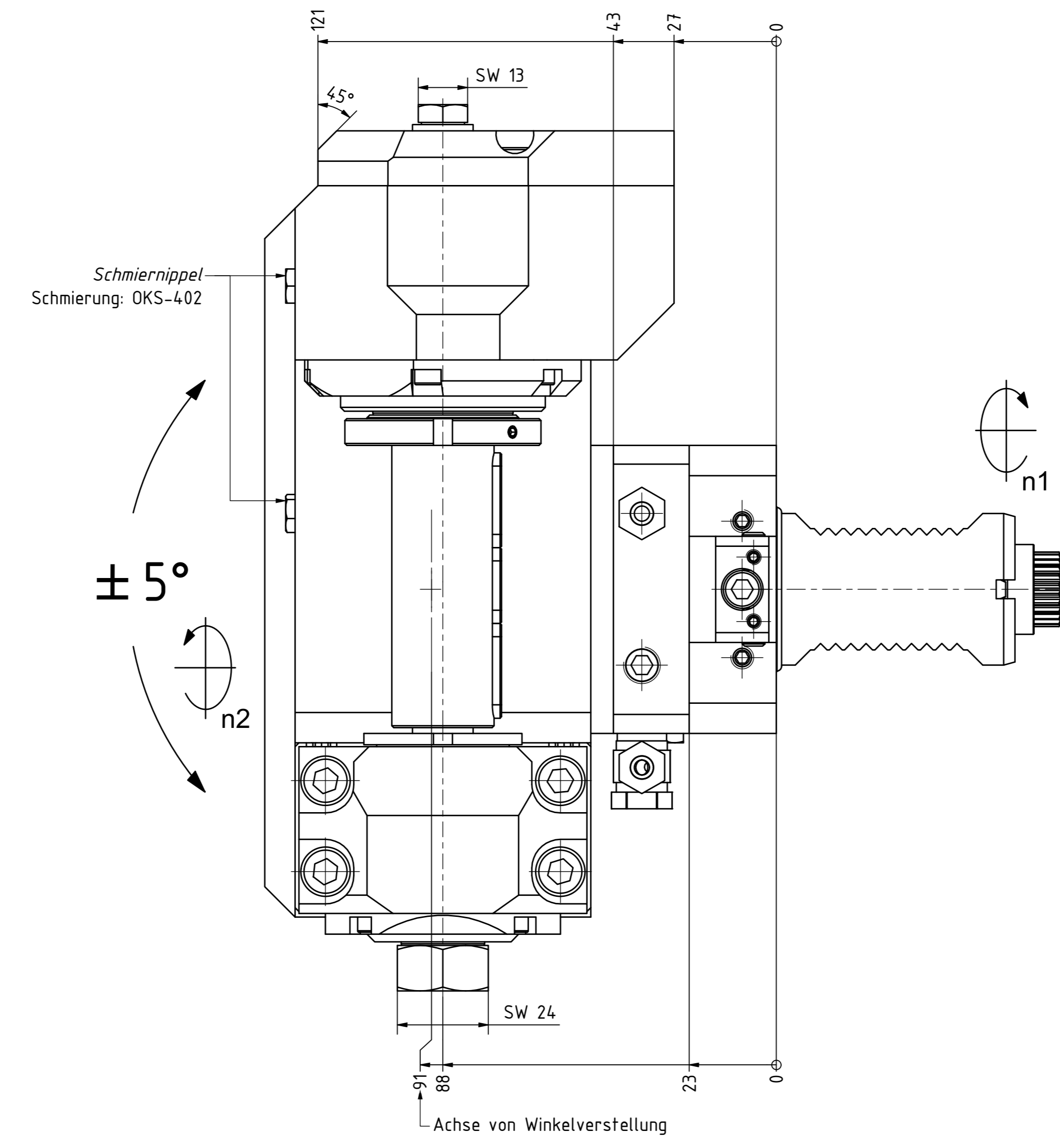
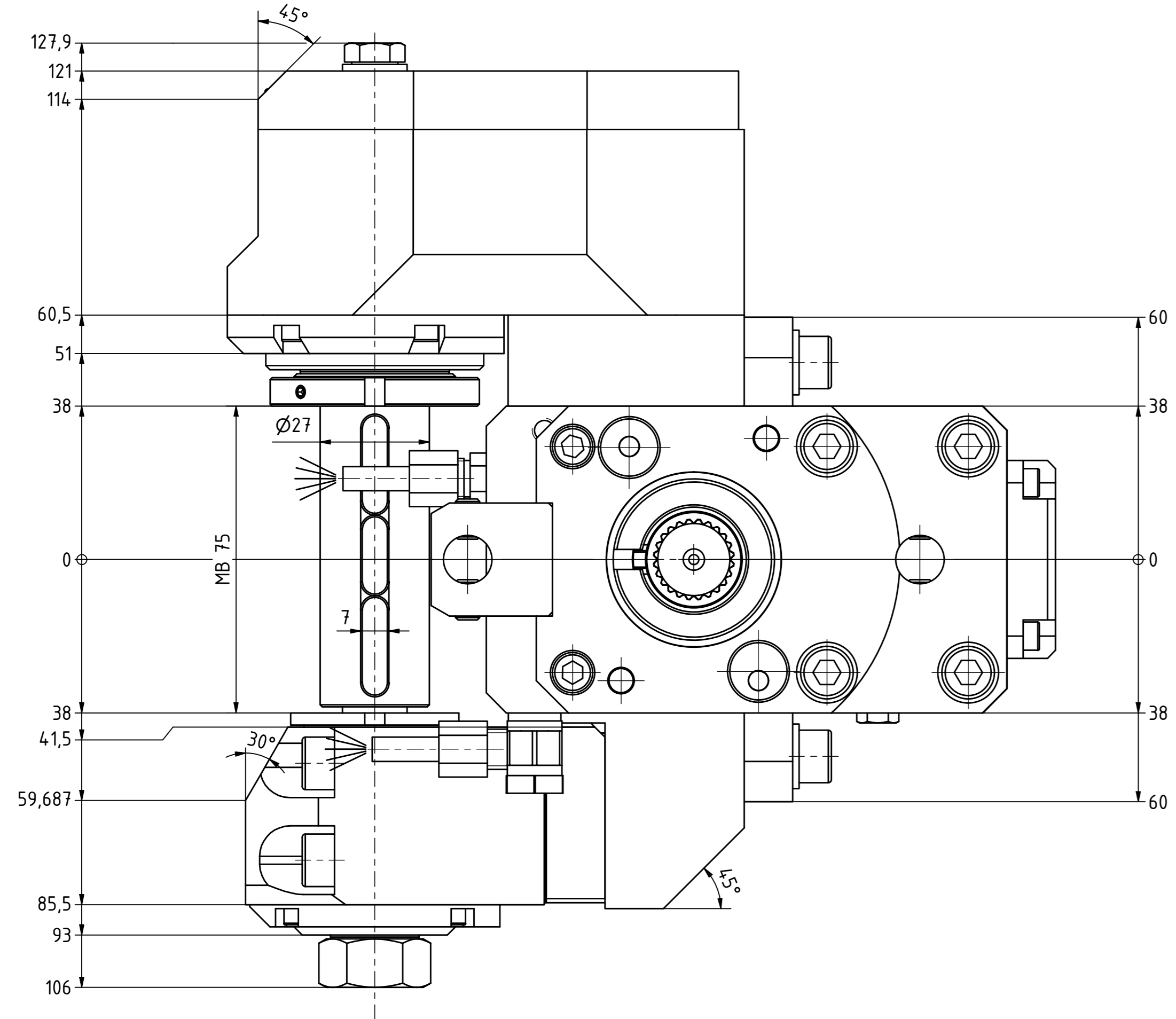

Fraeserwelle austauschbar
Spindle removable

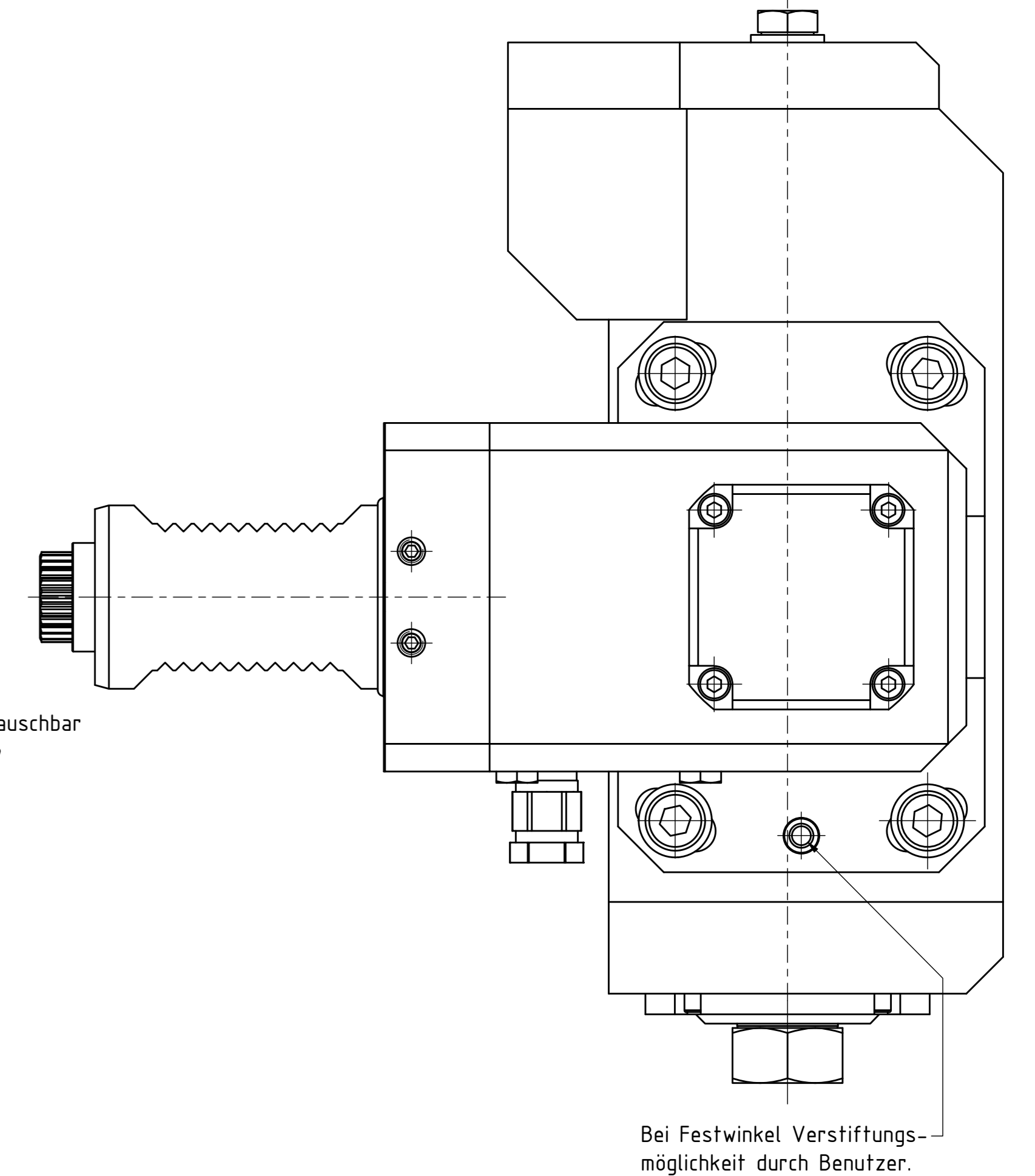

Bei Festwinkel Versteifungs-
möglichkeit durch Benutzer.

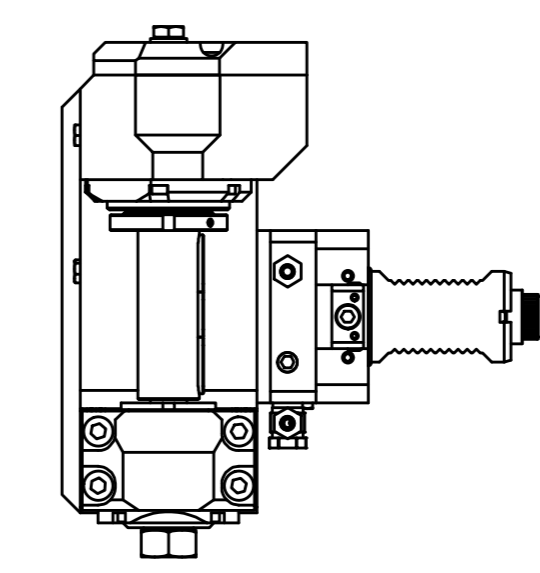
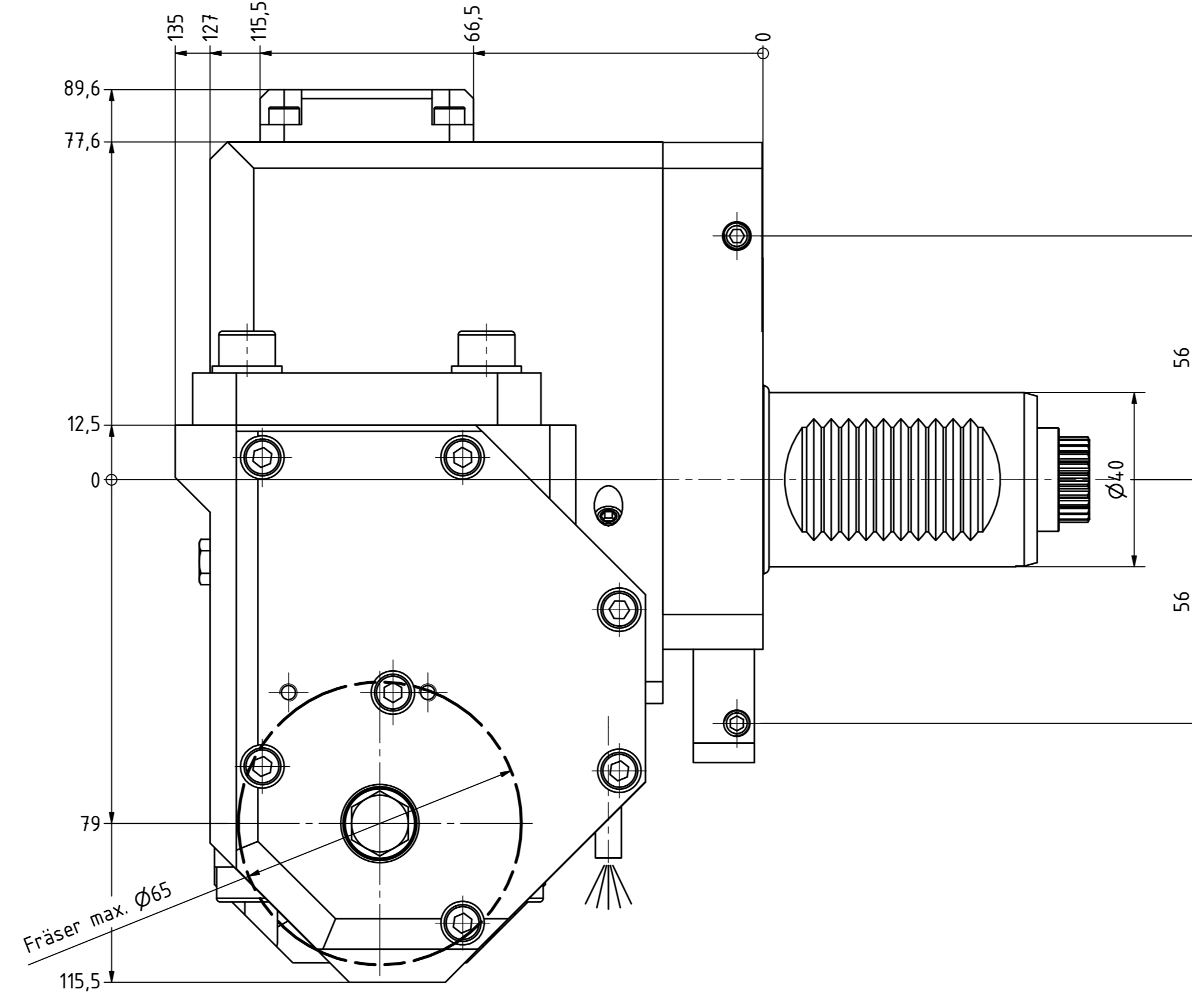
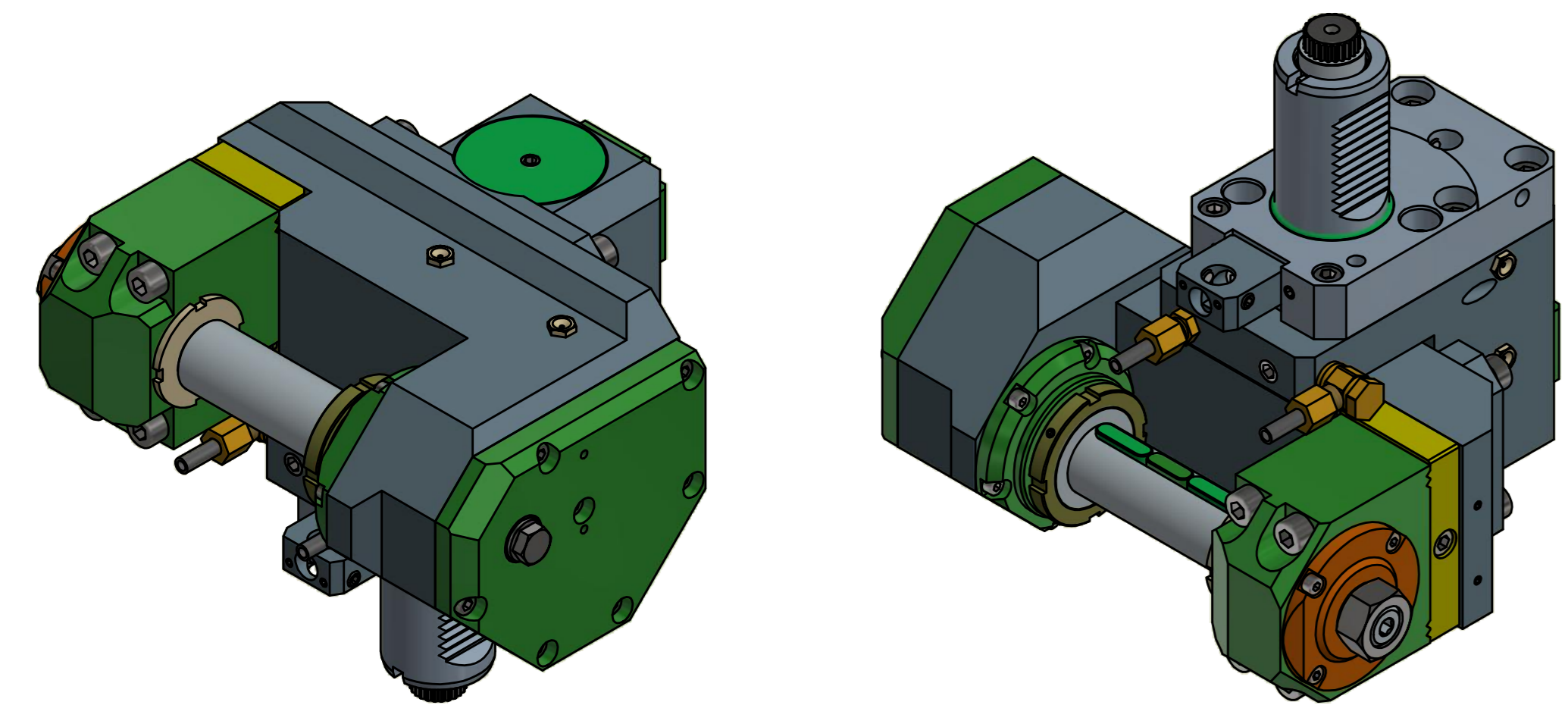

Doppelverzahnung Lizenz Traub
double tooth system licence Traub

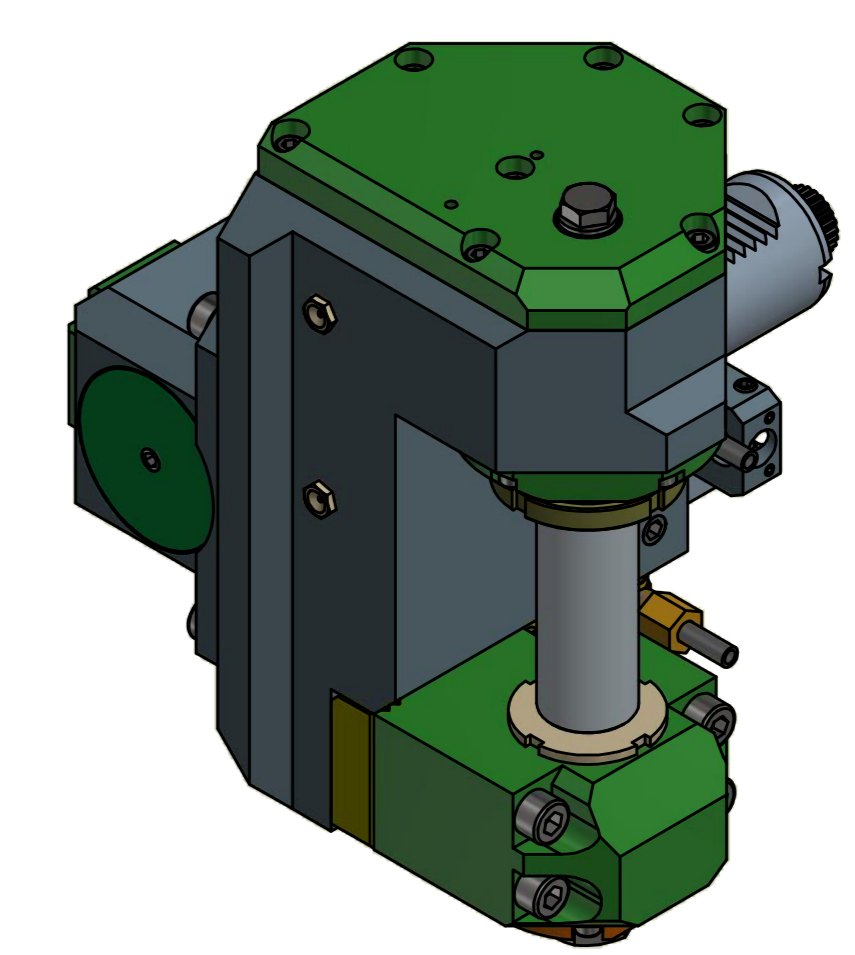

Beide Nachbarstationen nicht verwendbar!
Both neighbour stations are not useable!

Technische Daten - Technical data
Gewicht = 13.866 kg
Torque max (n1/n2) = 50 / 50 Nm
Speed max (n1/n2) = 6000 / 6000 1/min
Gear ratio (i)=n1/n2 = 1:1
mit Kegelrollenlager
with taper roller bearings

Radial Scheibenfräserkopf versetzt
Saw milling spindle offset

EWS
84.4027CTXRLTKWZ79MB75
162493

Copyright EWS Tool Technologies
Weitergabe und Vervielfältigung dieser Unterlagen,
Vervielfältigung und Mitteilung ohne schriftliche
Genehmigung, soweit nicht ausdrücklich zugestanden,
Zusammenfassungen vorbehalten zu Schadenersatz.

