

Spannzange / collet ER25 DIN6499
Spannbereich / clamping range: 1,0 - 16,0

Gewindebohrzange / tapping collet
ET-1-25 M3-M12

Doppelverzahnung Lizenz Traub
double tooth system licence Traub

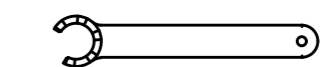
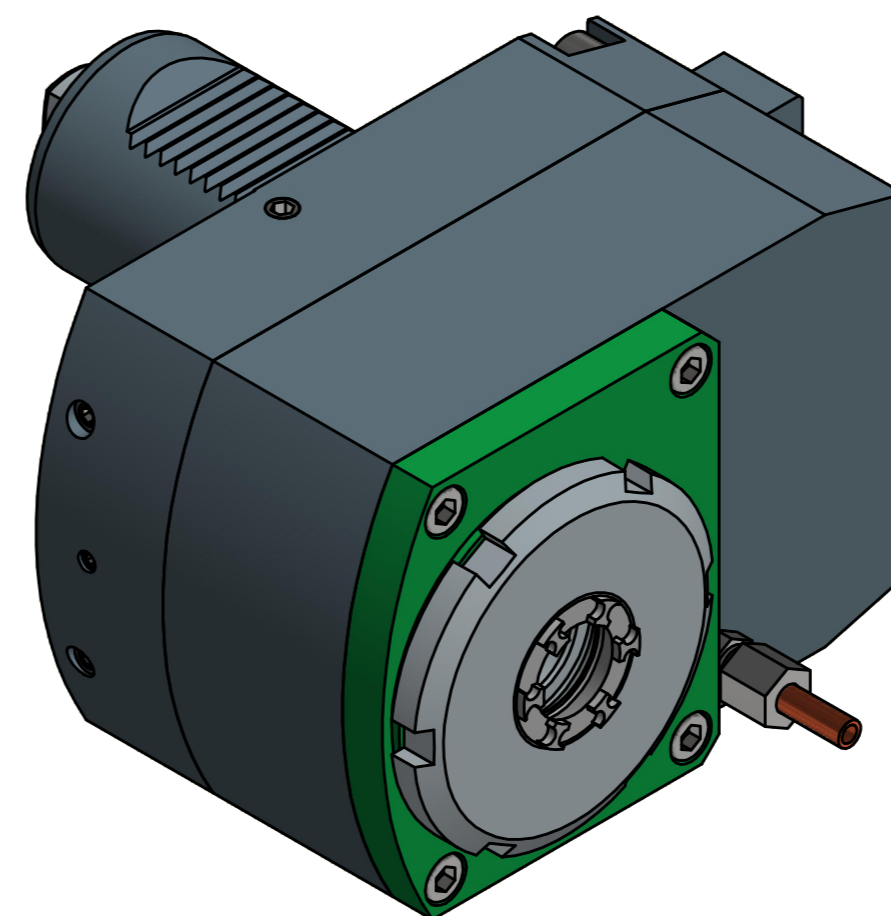
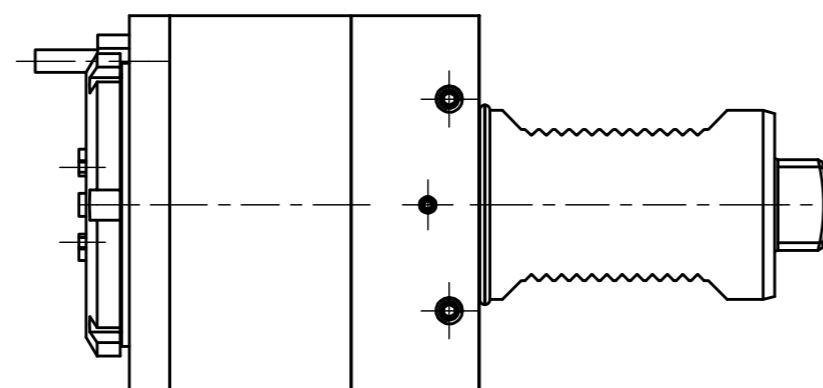

Spannzangenschlüssel für
innenliegende Mutter
Clamping wrench for
internal collet
225AX

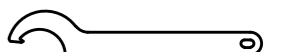

Hakenschlüssel
mit Nase
Hook wrench with
nose end
DIN1810 A 80x90

Copyright EWS Tool Technologies
Weitergabe und Vervielfältigung dieser Unterlage,
Verwertung und Mitteilung ihres Inhalts nicht
gestattet, soweit nicht ausdrücklich zugestanden.
Zuwerhandlungen verpflichten zu Schadenersatz.

Bemerkung - Note

Technische Daten - technical data

Weight = 10.320 [kg]
Torque max. (M1/M2) = 90 / 30 [Nm]
Speed max. (n1/n2) = 4200 / 12600 [1/min]
Gear ratio (i)=n1:n2 = 1:3

Benennung - Title

Axial Bohr u. Fräskopf achsversetzt
Ax. drill. and mill. head offset



Nr. - No.
50.50251809RL131M

Technische Änderungen vorbehalten!
Subject to technical modifications!
IDENT: D-EWS-183215

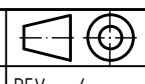

REV: -/-
MNR.
182375

