

Spannzange / collet ER20 DIN6499
 Spannungsbereich / clamping range: 1,0 - 13,0

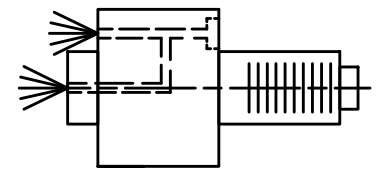

Innen- und Aussenkuehlung / Inside and outside coolant supply
 Kein Trockenlauf / No dry run
 Kuehlmittelfiltrierung 50μ / coolant filtration 50μ

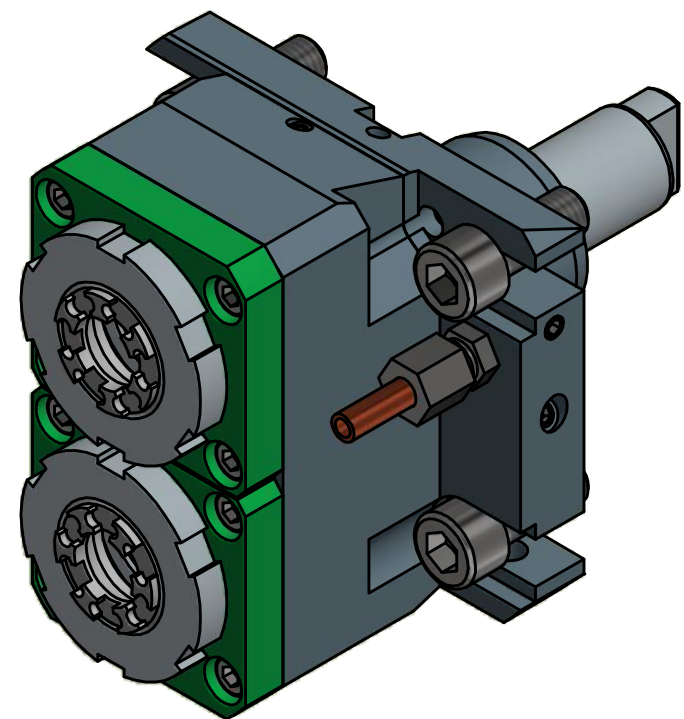
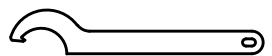

 Hakenschlüssel mit Nase
 Hook wrench with nose end
 DIN1810 A 45x50

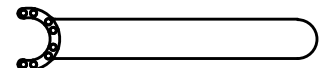
 Spannzangenschlüssel für innenliegende Mutter
 Clamping wrench for internal collet
 EA 20 K

Copyright **EWS Tool Technologies**
 Weitergabe und Vervielfaeltigung dieser Unterlage, Verwertung und Mitteilung ihres Inhalts nicht gestattet, soweit nicht ausdrecklich zugestanden. Zuwiderhandlungen verpflichten zu Schadenersatz.

Bemerkung - Note
 Nicht ohne Kuehlmittel betreiben!
 Not for use without coolant-fluid!

Technische Daten - technical data	
Weight	= 3.551 [kg]
Torque max. (M1/M2)	= 25 / 12.5 / 12.5 [Nm]
Speed max. (n1/n2)	= 6000 / 6000 / 6000 [rpm]
Gear ratio (i)=n1:n2	[1/n1] 1:1
Pressure (pmax)	= 70 [bar]

Benennung - Title
Axial Bohr und Fräskopf
 Axial drilling and milling head

EWS Tool Technologies
 EWS Weigle GmbH & Co. KG
 Maybachstr. 1
 D-73066 Uehingen
 www.ews-tools.de

Technische Aenderungen vorbehalten!
 Subject to technical modifications!
 IDENT: DEWS104117
 Nr. - No. 40.4020DYTS4000V20IKTK50

REV: -/B
 MNR. 182149

