

Doppelverzahnung Lizenz Traub
double tooth system licence Traub

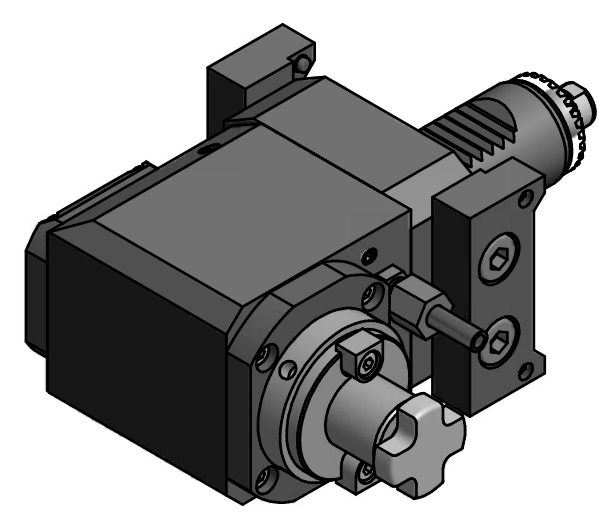

Hakenschlüssel
mit Zapfen
Hook wrench
with fixed pin
DIN1810 B 45x50

Copyright **EWS Tool Technologies**
Weitergabe und Vervielfaeltigung dieser Unterlage,
Verwertung und Mitteilung ihres Inhalts nicht
gestattet, soweit nicht ausdruuecklich zugestanden.
Zuwiderhandlungen verpflichten zu Schadenersatz.

<p>Bemerkung - Note mit Kegelrollenlager with taper roller bearing(s)</p>	<p>Technische Daten - technical data M₁ / M₂ = 20 / 40 Nm n₁ / n₂ = 6000 / 3000 1/min i (N₁:N₂) = 2:1</p>	<p>Benennung - Title Radial Fräskopf <i>Radial milling head</i></p>	<table border="1"> <tr> <th>name</th> <th>date</th> </tr> <tr> <td>Rogler</td> <td>13.05.2015</td> </tr> </table>	name	date	Rogler	13.05.2015	<p>Technische Aenderungen vorbehalten! Subject to technical modifications!</p> <p>Nr. 62.3022KRTNC65RLI2</p>	<p>DIN A3</p>
name	date								
Rogler	13.05.2015								
			<p>EWS EWS Weigete GmbH & Co. KG Maybachstr. 1 D-73066 Uhingen Tel. +49(0)7161/93040-100</p>	<p>MNR: 181927 IDENT: D-EWS-179287 -</p>	<p>Blatt - page 1 (1)</p>				