

Spannzange / collet ER25 DIN6499  
Spannbereich / clamping range: 1,0 - 16,0

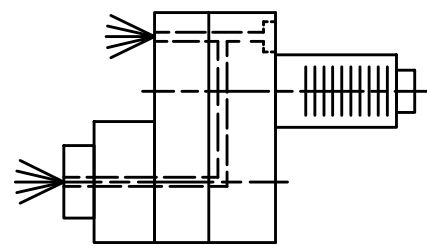

Innen- und Aussenkuehlung / Inside and outside coolant supply  
Kuehlmittelfiltrierung <math>< 50\mu</math> / coolant filtration <math>< 50\mu</math>

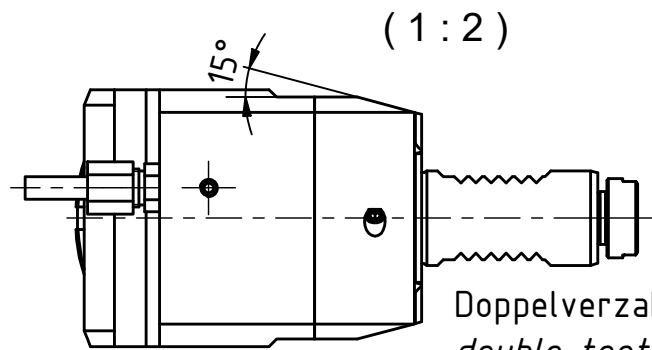

Doppelverzahnung Lizenz Traub  
double tooth system licence Traub

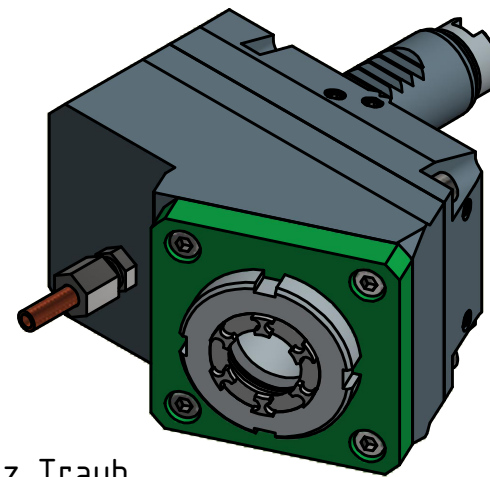

Hakenschlüssel  
Hook wrench with nose  
DIN1810 A 45x50  
Spannzangenschlüssel für innenliegende Mutter  
Clamping wrench for internal collet  
225AX

Copyright EWS Tool Technologies  
Weitergabe und Vervielfaeltigung dieser Unterlage, Verwertung und Mitteilung ihres Inhalts nicht gestattet, soweit nicht ausdrecklich zugestanden. Zuwiderhandlungen verpflichten zu Schadenersatz.

Bemerkung - Note  
Für Trockenlauf geeignet!  
Use without coolant fluid allowed!

Technische Daten - technical data  
Weight = 3.745 [kg]  
Torque max. (M1/M2) = 25 / 25 [Nm]  
Speed max. (n1/n2) = 8000 / 8000 [1/min]  
Gear ratio (i)=n1:n2 = 1:1  
Pressure (pmax) = 70 [bar]

Benennung - Title  
Radial Bohr und Fräskopf  
Radial drilling and milling head

**EWS** Tool Technologies  
EWS Weigele GmbH & Co. KG  
Maybachstr. 1  
D-73066 UHINGEN  
www.ews-tools.de

Technische Aenderungen vorbehalten!  
Subject to technical modifications!

IDENT: D-EWS-081151

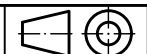

REV: -/A

Nr. - No.

60.2525G200RLIKDWTW25IM

MNR.

147650

