

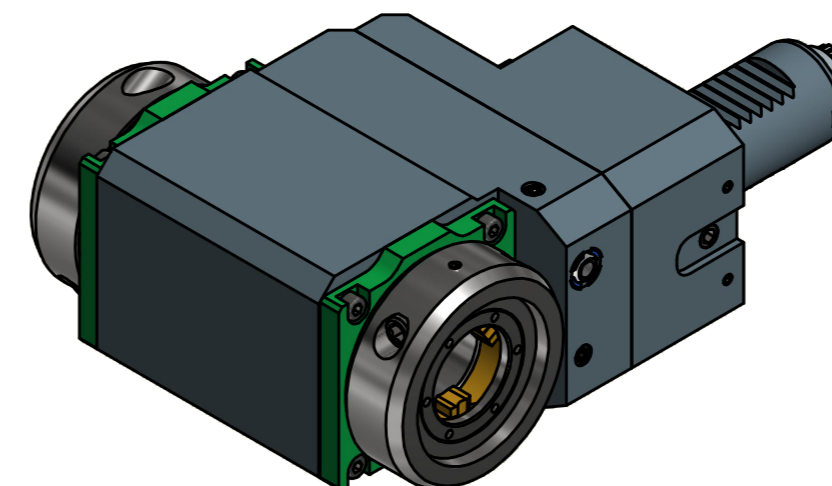
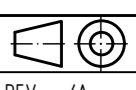

Doppelverzahnung Lizenz Traub
double tooth system licence Traub

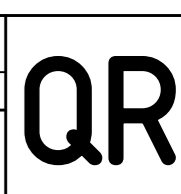

Copyright **EWS Tool Technologies**
Weitergabe und Vervielfältigung dieser Unterlage,
Verwertung und Mitteilung ihres Inhalts nicht
gestattet, soweit nicht ausdrücklich zugestanden.
Zuwerhandlungen verpflichten zu Schadenersatz.

Bemerkung - Note	Technische Daten - technical data Weight = 6.248 [kg] Torque max. (M1/M2) = 24 / 12 12 [Nm] Speed max. (n1/n2) = 6000 / 12000 12000 [1/min] Gear ratio (i)=n1:n2 = 1:2 1:2	Benennung - Title Radial Bohr und Fräskopf, zurückges Radial drill. and mill. head offset	 EWS Weigle GmbH & Co. KG Maybachstr. 1 D-73066 Uhlingen www.ews-tools.de	Technische Änderungen vorbehalten! Subject to technical modifications! IDENT: DEWS145632 Nr. - No. 80.30VX3LDCTXRL1	 REV: -/A 181771	
------------------	--	---	---	--	--	---