

Spannzange / collet ER25 DIN6499  
Spannbereich / clamping range: 1,0 - 16,0

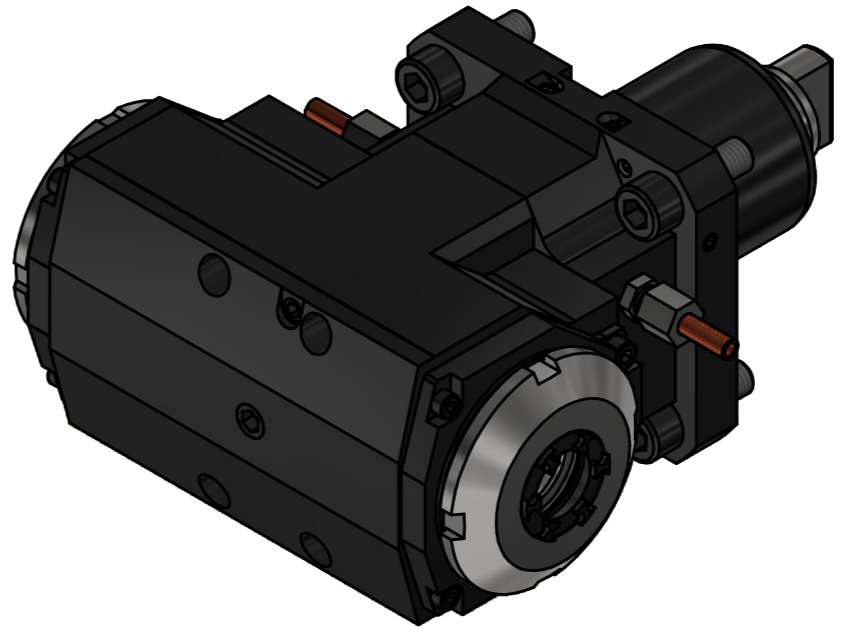

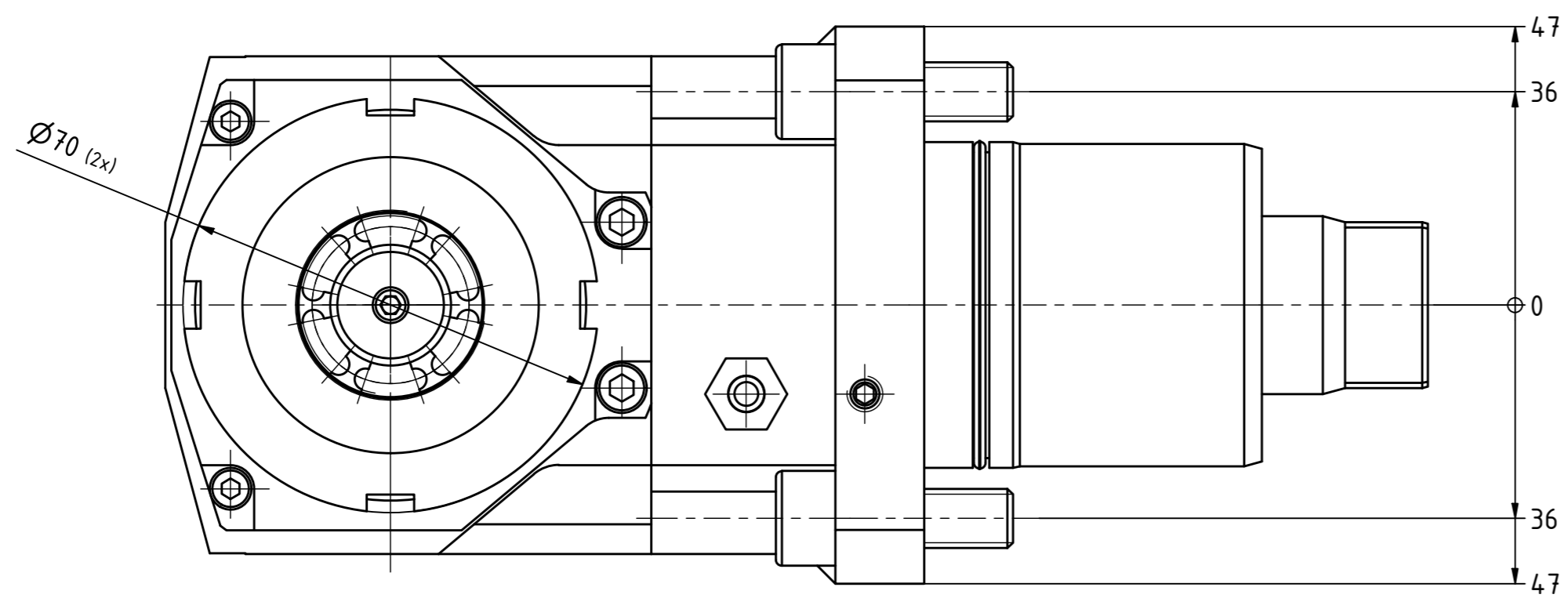
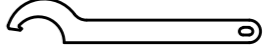
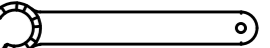
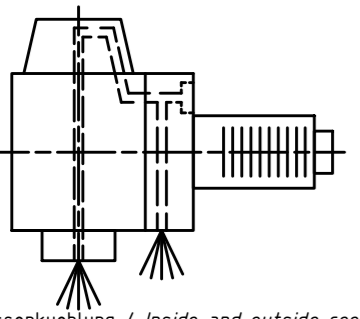

 Hakenschlüssel  
mit Nase  
Hook wrench with  
nose end  
DIN1810 A 68x75

 Spannzangenschlüssel für  
innenliegende Mutter  
Clamping wrench for  
internal collet  
225AX

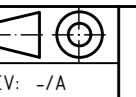

Innen- und Aussenkuehlung / Inside and outside coolant supply  
Kein Trockenlauf / No dry run  
Kuehlmittelfiltrierung+50µ / coolant filtration+50µ

Bemerkung - Note Nicht ohne Kuehlmittel betreiben! Not for use without coolant-fluid!	Technische Daten - technical data Weight = 10.151 [kg] Torque max. (M1/M2) = [Nm] Speed max. (n1/n2) = [1/min] Gear ratio (i)=n1:n2 = Pressure (pmax) = [bar]	Benennung - Title <b>Radial Bohr und Fräskopf</b> <b>Radial drilling and milling head</b>	 <b>EWS</b> Weigle GmbH & Co. KG Maybachstr. 1 D-73066 Uhlingen www.ews-tools.de	Technische Aenderungen vorbehalten! Subject to technical modifications! IDENT: DEWS258019 Nr. - No. <b>60.5525DTS4000V15IKIM</b>	 REV: -/A MNR. <b>181695</b>	
---	--	---	--	--	---	---

Copyright **EWS Tool Technologies**  
Weitergabe und Vervielfaeltigung dieser Unterlage,  
Verwertung und Mitteilung ihres Inhalts nicht  
gestattet, soweit nicht ausdrecklich zugestanden.  
Zuwiderhandlungen verpflichten zu Schadenersatz.