

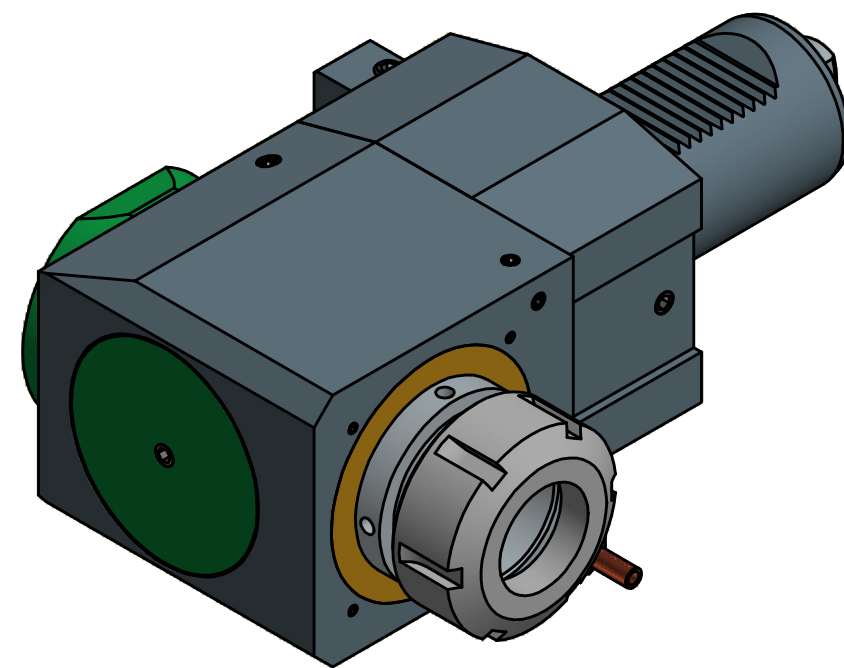

Doppelverzahnung Lizenz Traub
double tooth system licence Traub



Copyright **EWS Tool Technologies**
Weitergabe und Vervielfältigung dieser Unterlage,
Verwertung und Mitteilung ihres Inhalts nicht
gestattet, soweit nicht ausdrücklich zugestanden.
Zuwerhandlungen verpflichten zu Schadenersatz.

Bemerkung - Note	Technische Daten - technical data Weight = 10,185 [kg] Torque max. (M1/M2) = 100 / 100 [Nm] Speed max. (n1/n2) = 4000 / 4000 [1/min] Gear ratio (i)=n1:n2 = 1:1	Benennung - Title Radial Bohr und Fräskopf Radial drilling and milling head	 EWS Weigle GmbH & Co. KG Maybachstr. 1 D-73066 Ulm/ingen www.ews-tool.de	Technische Änderungen vorbehalten! Subject to technical modifications! IDENT: D-EWS-180546 Nr. - No. 60.50401809RLGLPIN63X110 MNR. 181612 REV: -/-
------------------	---	---	--	---

