

2 zurückgesetzte Werkzeuge
 können nicht nebeneinander platziert werden!
 Einschränkung gilt nicht für C200!
 2 radial drill. and mill.head with offset
 can not be used side by side!
 Limitation does not apply to C200!

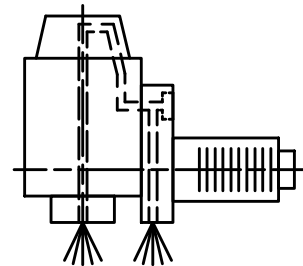
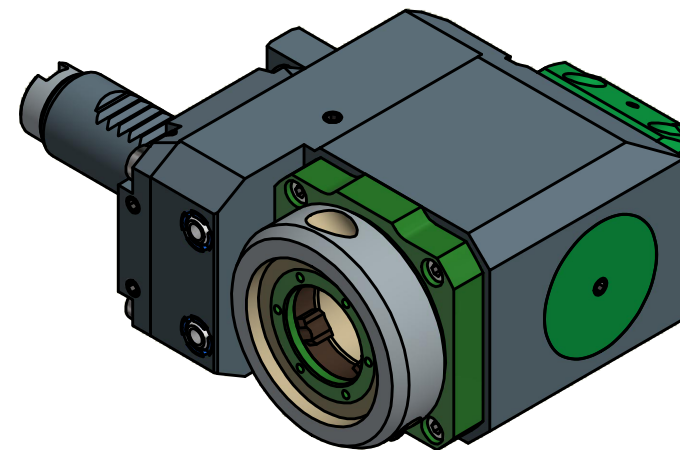

Innen- und Aussenkuehlung / Inside and outside coolant supply
 Kein Trockenlauf / No dry run
 Kuehlmittelfiltrierung50μ / coolant filtration50μ

Copyright **EWS Tool Technologies**
 Weitergabe und Vervielfaeltigung dieser Unterlage,
 Verwertung und Mitteilung ihres Inhalts nicht
 gestattet, soweit nicht ausdrecklich zugestanden.
 Zuwiderhandlungen verpflichten zu Schadenersatz.

<p>Bemerkung - Note</p> <p>Nicht ohne Kuehlmittel betreiben! <i>Not for use without coolant-fluid!</i></p>	<p>Technische Daten - technical data</p> <p>Weight = 4.583 [kg] Torque max. (M1/M2) = 25 / 25 [Nm] Speed max. (n1/n2) = 8000 / 8000 [1/min] Gear ratio (i)=n1:n2 = 1:1 Pressure (pmax) = 70 [bar]</p>	<p>Benennung - Title</p> <p>Radial Bohr und Fräskopf, zurückges Radial drill. and mill. head offset</p>	<p>EWS Tool Technologies</p> <p>EWS Weigele GmbH & Co. KG Maybachstr. 1 D-73066 Uthingen www.ews-tools.de</p>	<p>Technische Aenderungen vorbehalten! <i>Subject to technical modifications!</i></p> <p>IDENT: D-EWS-147301</p>	<p>REV: -/-</p> <p>MNR.</p> <p>162107</p>	<p>QR</p>
---	---	--	--	---	---	------------------