

min. 63,5
max. 67

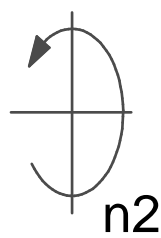

Spannzange / collet ER25 DIN6499
Spannbereich / clamping range: 1,0 - 16,0

Gewindebohrzange / tapping collet
ET-1-25 M3-M12

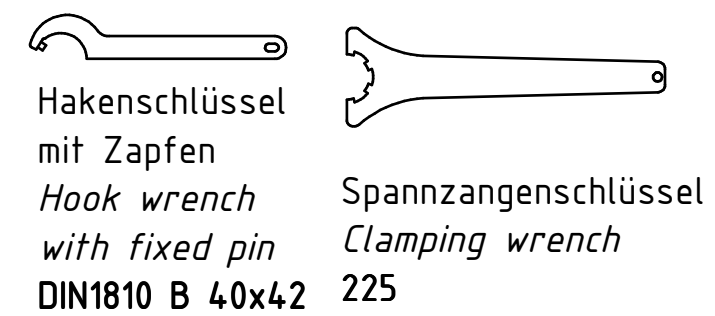
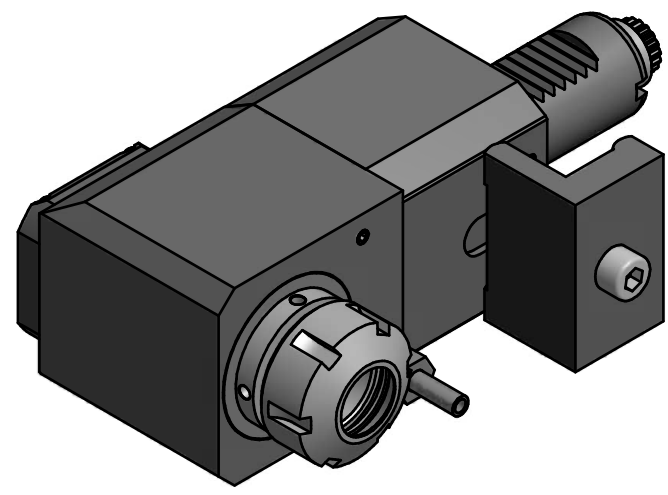

Copyright **EWS Tool Technologies**
Weitergabe und Vervielfaeltigung dieser Unterlage,
Verwertung und Mitteilung ihres Inhalts nicht
gestattet, soweit nicht ausdrecklich zugestanden.
Zuwiderhandlungen verpflichten zu Schadenersatz.

| | | | | | | |
|------------------|---|---|---|---------------|--|--------------------|
| Bemerkung - Note | Technische Daten - technical data M1 / M2 = 25 / 25 Nm n1 / n2 = 8000 / 8000 1/min i (N1:N2) = 1:1 | Benennung - Title Radial Bohr und Fräskopf <i>Radial drilling and milling head</i> | name | date | Technische Aenderungen vorbehalten! Subject to technical modifications! | |
| | | | drawing | M. Simoniello | | |
| | | | EWS Weigte GmbH & Co. KG Maybachstr. 1 D-73066 Uhingen Tel. +49(0)7161/93040-100 | | Nr. 60.3025LCTXROT08 | DIN A3 |
| | | | MNR: 111887 | | IDENT: D-EWS-186688 - | Blatt - page 1 (1) |