

Innen- und Aussenkuehlung / Inside and outside coolant supply  
 Kein Trockenlauf / No dry run  
 Kuehlmittelfiltrierung <math>50\mu</math> / coolant filtration <math>50\mu</math>

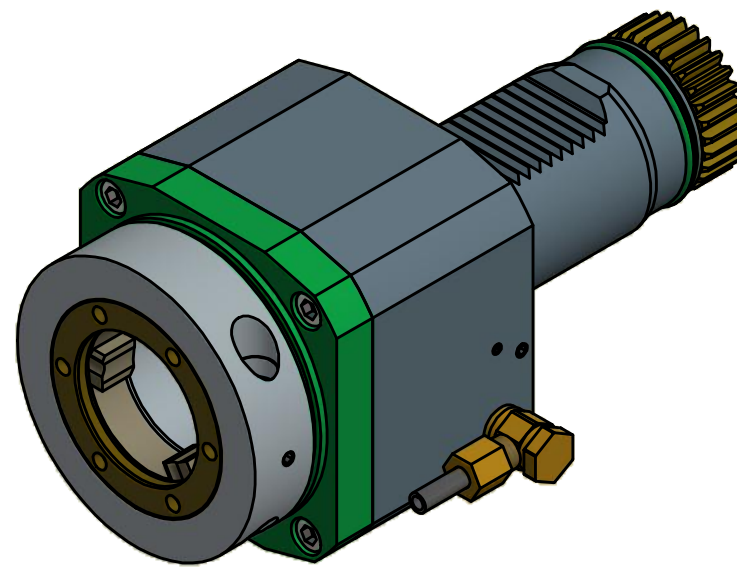

Copyright **EWS Tool Technologies**  
 Weitergabe und Vervielfaeltigung dieser Unterlage,  
 Verwertung und Mitteilung ihres Inhalts nicht  
 gestattet, soweit nicht ausdrecklich zugestanden.  
 Zuwiderhandlungen verpflichten zu Schadenersatz.

<p>Bemerkung - Note</p> <p>Nicht ohne Kuehlmittel betreiben!  <i>Not for use without coolant-fluid!</i></p>	<p>Technische Daten - technical data</p> <p>Weight = 6.278 [kg]          Torque max. (M1/M2) = 100 / 100 [Nm]          Speed max. (n1/n2) = 4000 / 4000 [1/min]          Gear ratio (i)=n1:n2 = 1:1          Pressure (pmax) = 25 [bar]</p>	<p>Benennung - Title</p> <p>Axial Bohr und Fräskopf  <i>Axial drilling and milling head</i></p>	<p><b>EWS</b>          Tool Technologies</p> <p><small>EWS Weigle GmbH &amp; Co. KG          Maybachstr. 1          D-73066 Uehingen          www.ews-tools.de</small></p> <p>Nr. - No.  <b>40.50V5TNA600IK</b></p>	<p>Technische Aenderungen vorbehalten!  <i>Subject to technical modifications!</i></p> <p>IDENT: DEWS016220</p> <p>MNR.  <b>131930</b></p>	<p>REV: -/A</p> <p><b>QR</b></p>
---	---	---	---	--	----------------------------------