

Spannzange / collet ER32 DIN6499
 Spannereich / clamping range: 2,0 - 20,0

Gewindebohrzange / tapping collet
 ET-1-32 M5-M12

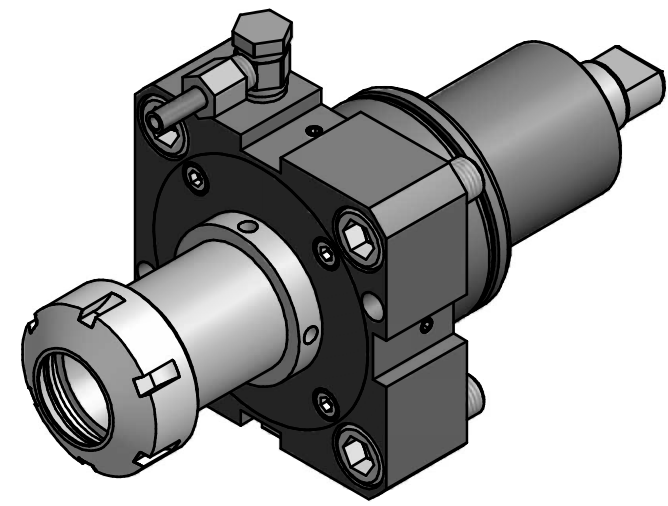
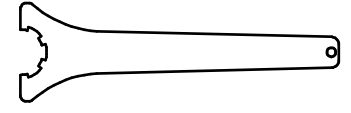

 Hakenschlüssel
 mit Zapfen
 Hook wrench
 with fixed pin
 DIN1810 B 45x50

 Spannzangenschlüssel
 Clamping wrench
 232

Copyright **EWS Tool Technologies**
 Weitergabe und Vervielfältigung dieser Unterlage,
 Verwertung und Mitteilung ihres Inhalts nicht
 gestattet, soweit nicht ausdrücklich zugestanden.
 Zuwiderhandlungen verpflichten zu Schadenersatz.

Bemerkung - Note	Technische Daten - technical data M1 / M2 = 50 / 50 Nm n1 / n2 = 6000 / 6000 1/min i (N1:N2) = 1:1	Benennung - Title Axial Bohr und Fräskopf <i>Axial drilling and milling head</i>	name	date	Technische Änderungen vorbehalten! Subject to technical modifications!	 Nr. 40.65321809S01 File: 40.65321809S01_OUT.idw
			drawing	12.02.2007		
			Blatt - page 1 (1)			