

Spannzange / collet ER25 DIN6499
 Spannungsbereich / clamping range: 1,0 - 16,0

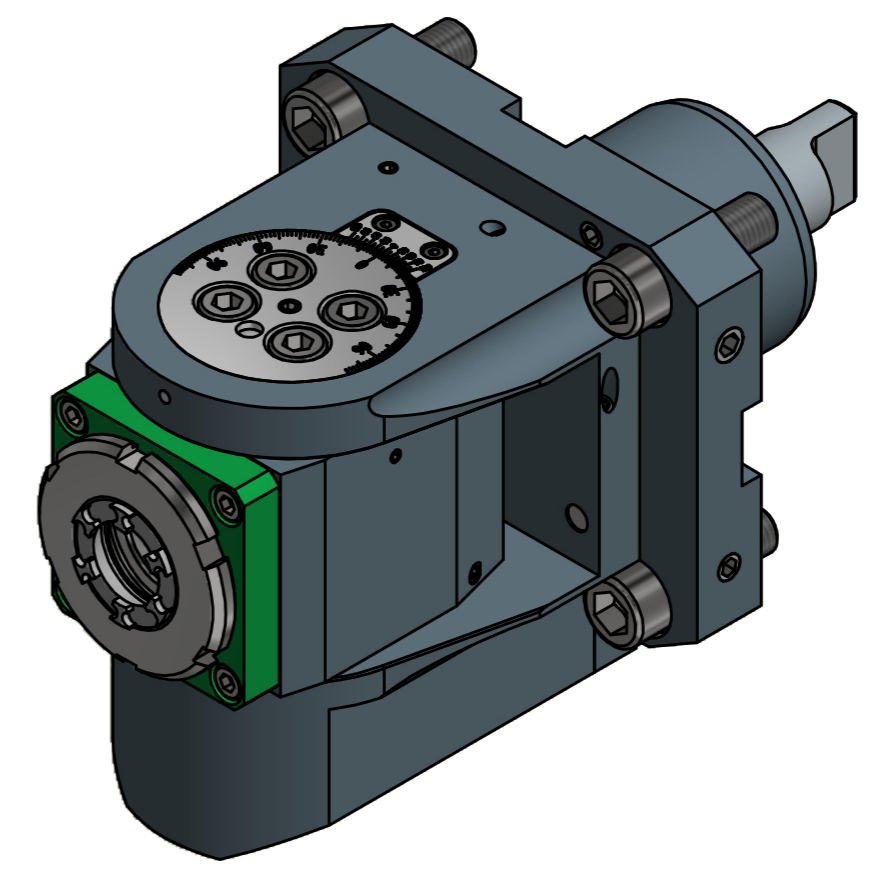

 
 Hakenschlüssel mit Nase / Hook wrench with nose end
 Spannzangenschlüssel für innenliegende Mutter / Clamping wrench for internal collet
 DIN1810 A 58x62 / 225AX

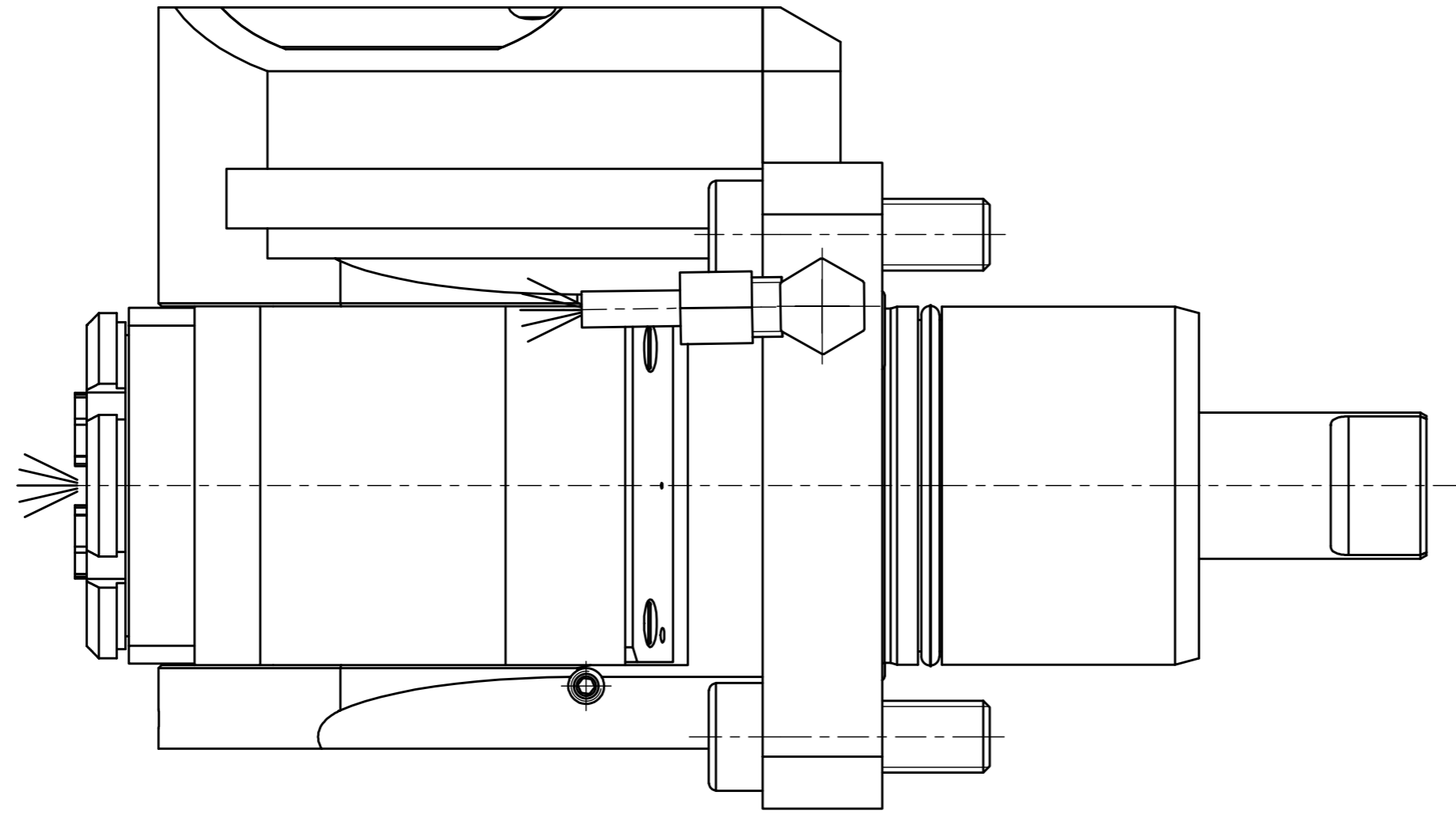
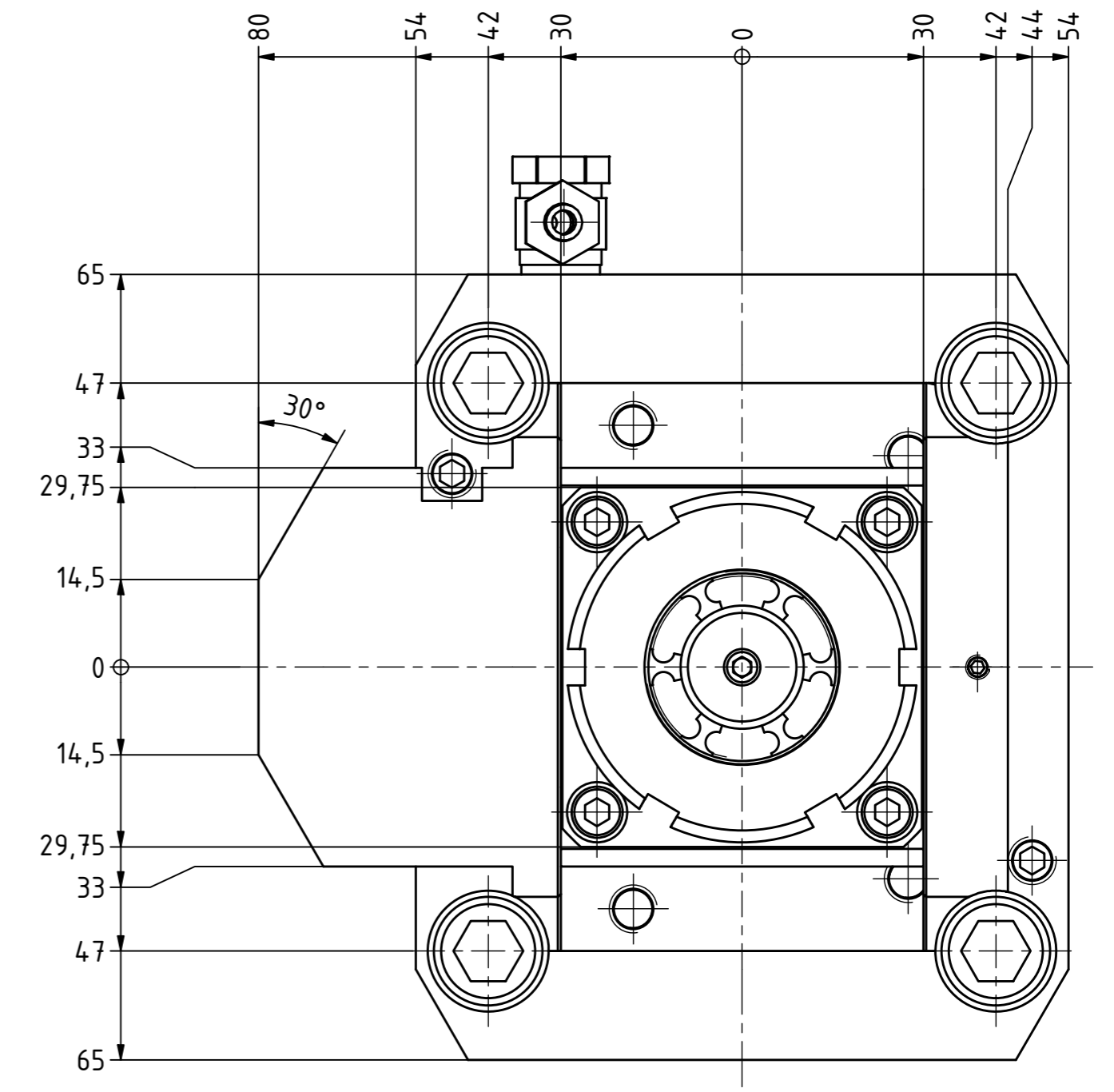
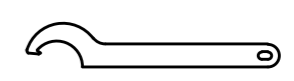
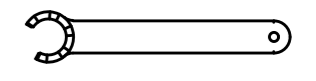
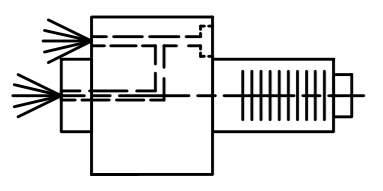

Innen- und Aussenkuehlung / Inside and outside coolant supply
 Kuehlmittelfiltrierung=50µ / coolant filtration=50µ

Copyright **EWS Tool Technologies**
 Weitergabe und Vervielfaeltigung dieser Unterlage, Verwertung und Mitteilung ihres Inhalts nicht gestattet, soweit nicht ausdrecklich zugestanden. Zuwiderhandlungen verpflichten zu Schadenersatz.

Bemerkung - Note Für Trockenlauf geeignet! Use without coolant fluid allowed!	Technische Daten - technical data Weight = 8,948 [kg]	Benennung - Title Schwenkkopf Swivel head
	Torque max. (M1/M2) = 20 / 20 [Nm]	
	Speed max. (n1/n2) = 6000 / 6000 [1/min]	
	Gear ratio (i)=n1:n2 = 1:1	
	Pressure (pmax) = 70 [bar]	

EWS Tool Technologies <small>EWS Weigle GmbH & Co. KG Maybachstr. 1 D-73066 Uhingen www.ews-tools.de</small>	Technische Aenderungen vorbehalten! Subject to technical modifications! IDENT: DEWS024139	Nr. - No. 63.6025NLIKDIM	REV: -/A MNR. 145690	
	Copyright EWS Tool Technologies Weitergabe und Vervielfaeltigung dieser Unterlage, Verwertung und Mitteilung ihres Inhalts nicht gestattet, soweit nicht ausdrecklich zugestanden. Zuwiderhandlungen verpflichten zu Schadenersatz.			