

Spannzange / collet ER32 DIN6499  
 Spannbereich / clamping range: 2,0 - 20,0

Gewindebohrzange / tapping collet  
 ET-1-32 M5-M12

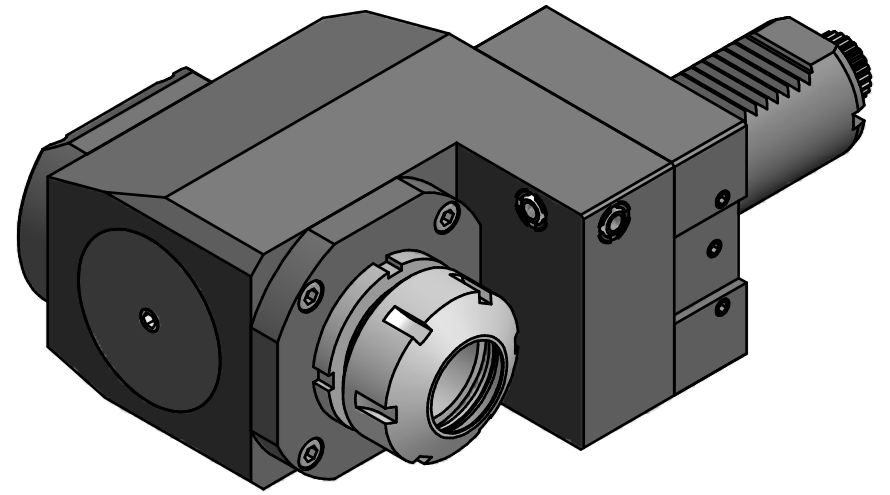
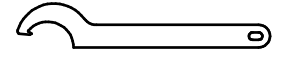

  
 Hakenschlüssel  
 mit Nase  
 Hook wrench with  
 nose end  
 DIN1810 A 45x50

  
 Spannzangenschlüssel  
 Clamping wrench  
 232

Copyright **EWS Tool Technologies**  
 Weitergabe und Vervielfältigung dieser Unterlage,  
 Verwertung und Mitteilung ihres Inhalts nicht  
 gestattet, soweit nicht ausdrücklich zugestanden.  
 Zuwiderhandlungen verpflichten zu Schadenersatz.

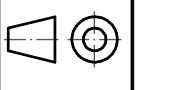
Bemerkung - Note	Technische Daten - technical data M1 / M2 = 50 / 75 Nm n1 / n2 = 6000 / 4000 1/min i (N1:N2) = 1,5:1	Benennung - Title <b>Radial Bohr und Fräskopf, zurückges</b> <b>Radial drill. and mill. head offset</b>	<table border="1"> <tr> <td>name</td> <td>date</td> </tr> <tr> <td>Theiss</td> <td>16.02.2015</td> </tr> </table>	name	date	Theiss	16.02.2015	Technische Aenderungen vorbehalten! Subject to technical modifications! Nr. <b>80.4032CTXRI151</b>	 DIN A3
name	date								
Theiss	16.02.2015								
MNR: 125047		IDENT: D-EWS-173360 -		Blatt - page 1 (1)					