

Spannzange / collet ER40 DIN6499
 Spannbereich / clamping range: 3,0 - 26,0

Gewindebohrzange / tapping collet
 ET-1-40 M6-M16

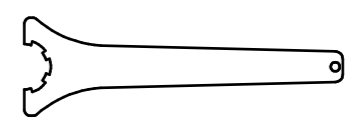

Spannzangenschlüssel
 Clamping wrench
 240

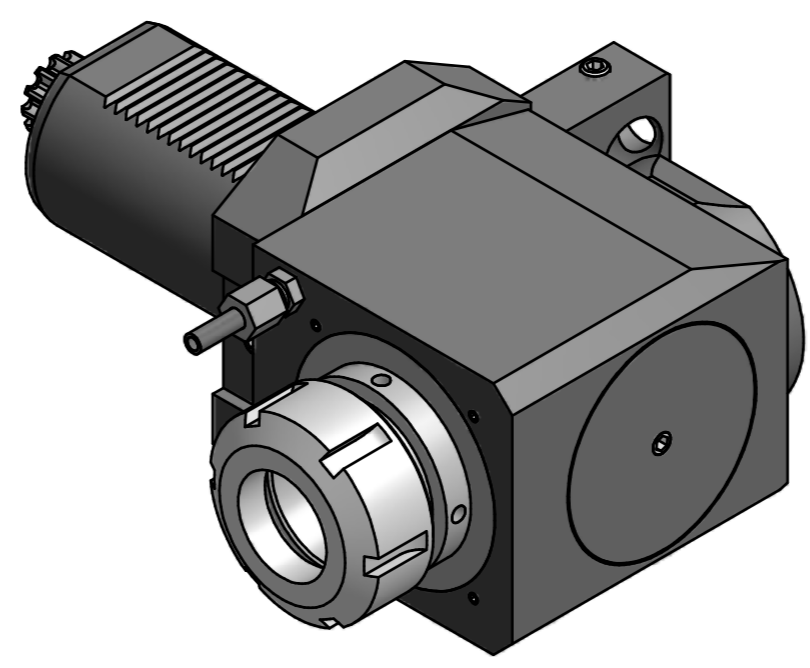
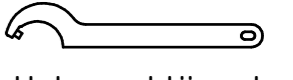

Hakenschlüssel
 mit Zapfen
 Hook wrench
 with fixed pin
 DIN1810 B 58x62

Copyright **EWS Tool Technologies**
 Weitergabe und Vervielfältigung dieser Unterlage,
 Verwertung und Mitteilung ihres Inhalts nicht
 gestattet, soweit nicht ausdrücklich zugestanden.
 Zuwiderhandlungen verpflichten zu Schadenersatz.

Bemerkung - Note	Technische Daten - Technical data	Benennung - Title		<table border="1"> <tr> <th>name</th> <th>date</th> </tr> <tr> <td>Theiss</td> <td>03.09.2014</td> </tr> </table>	name	date	Theiss	03.09.2014
	name	date						
Theiss	03.09.2014							
	M ₁ / M ₂ = 160 / 160 Nm n ₁ / n ₂ = 3000 / 3000 1/min i (N ₁ :N ₂) = 1:1	Radial Bohr und Fräskopf <i>Radial drilling and milling head</i>		Technische Änderungen vorbehalten! Subject to technical modifications! Nr. 60.60405482L <small>EWS Werkzeug GmbH & Co. KG Maybachstr. 1 D-72096 Ulm/lingen Tel. +49(0)7161/93040-100</small>				
				MNR: 131861 IDENT: D-EWS-162391 - Blatt - page 1 (1)				